

# JSBLFLP Series

## Compact, High Purity, Low Flow, Low Pressure, Back Pressure Regulating Valve

The JSBLFLP is a fully drainable compact back pressure regulator designed and built specifically for hygienic, ASME BPE low flow and low pressure gas and liquid applications.

- It's been designed specifically to eliminate all threaded connections and contaminant traps below the diaphragm.
- It is completely drainable (an industry first in compact hygienic regulator design), and compatible with CIP and SIP practices. See drainability guideline on page 6.
- The simple trim design facilitates quick trim change out and cleaning without valve removal or complete disassembly.

The durable valve body and metal trim components are machined from ASTM A479 316L SST barstock with wetted components and finished to ASME BPE SF5 (20Ra micro-inch (0,5 Ra  $\mu\text{m}$ ), electropolished) as standard. The valve is outfitted with the rugged Jorlon diaphragm and TFM or PEEK seats, all FDA approved, USP Class VI compliant materials. These materials of construction enable the JSBLFLP to withstand the rigors of continuous SIP and CIP processes if required.

### FEATURES

- Fully drainable with no threaded connections, or contaminant traps below the diaphragm
- In-line removable trim significantly reduces maintenance time
- Barstock construction guarantees material integrity and surface finish
- Minimized internal volume
- Proprietary Jorlon diaphragm material provides exceptionally long life and CIP/SIP capability, and FDA and USP Class VI compliance and is warranted for life.
- Soft seat material for ANSI Class VI shutoff

### DOCUMENTATION

The following documentation is shipped at no charge:

- Steriflow Unicert, a QC signed Certificate of Compliance for:
  - Material, listing heat numbers with attached MTR's
  - Surface Finish
  - FDA/USP Class VI - for all thermoplastic and elastomers
- Traceability:
  - Each individual product serial number is traceable to the Unicert serial number, heat numbers and attached MTR's

Other documents must be requested at time of RFQ, or order:

- ADI/TSE Free, Certified Test reports, Certificate of Origin.



### APPLICATIONS

#### Clean Compressed Air and Gas

Typically used in Biopharm or parenteral installations for modulating pressure relief during vessel filling, or for continuous low pressure sparge or blanket gas venting.

#### WFI, Buffer, Process Liquids

Can be used on liquid applications, but is not recommended. See drainability notice on page 4.

## SPECIFICATIONS

**Sizes:** 3/8" (DN10), 1/2" (DN15), 3/4" (DN20)

**Ends:** Tri-Clamp, Tube Weld End to ASME BPE, DIN or ISO dimensions as standard

**Soft Seat Materials for ANSI Class VI Shut-Off:**

- TFM to +450°F (232°C) FDA, USP Class VI
- PEEK to +350°F (177°C) FDA, USP Class VI

**Body and Wetted Component Material:**

ASME SA479 316L (UNS 31603) is standard. EN 10272:2000 GR 1.4435, AL-6XN®, Hastelloy®C-22 and others are optional.

**Diaphragm Material:** PTFE-based Jorlon; FDA, USP Class VI

**Maximum Inlet Pressure:**

- Weld-End, or Tri-Clamp Connections: 150 psig (10,5 barg)
- NPT Connections: 450 psig (31 barg)

**Spring Ranges:** 2 - 15 psi (0,14 - 1 bar); 10-25 psi (0,7 - 1,7 bar) 15 - 40 psi (1 - 2.8 bar)

Note: For a complete ancillary list of all wetted and non-wetted material specifications, please contact Steriflow Valve.

**Optional Cleaning Specifications:**

- Clean for Oil-Free
- O2 Cleaning complying with ASTM G93-03 2011 and CGA G-4.1-2009

**Flow Characteristics Cv (Kv):**

- Cv 0.05 (0,04); for relief valve sizing is 0.15(0,13)
- Cv 0.15(0,13); for relief valve sizing is 0.25(0,21)
- Cv 0.25(0,21); for relief valve sizing is 0.35(0,30)
- Cv 0.35(0,30); for relief valve sizing is 0.45(0,39)

**Surface Finish:**

- Internal wetted components: ASME BPE SF5, 20 Ra µin, (0,5 Ra µm) electropolished
- External: 40 Ra µin (1,0 Ra µm) electropolished
- Other finishes optional

**Options:**

- Panel Mounting
- Air Augment
- Inlet-Outlet Gauge

## OPTIONS

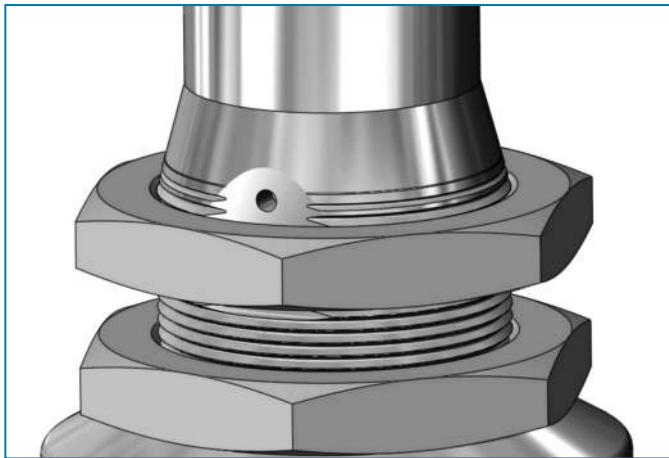

Panel Mount Option

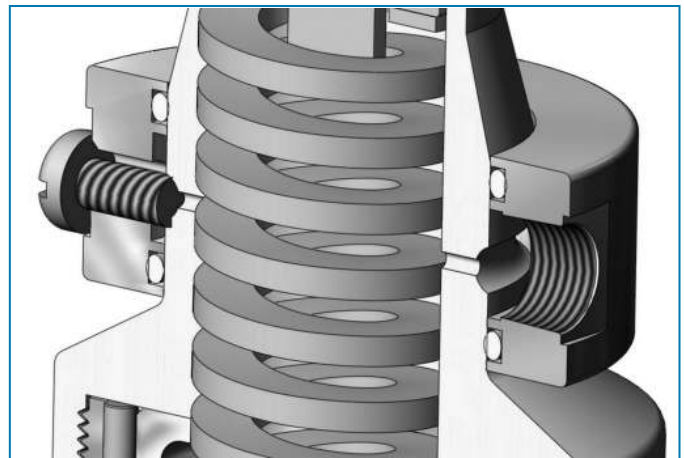

Air Augment Option (1/8" NPT)

## OPTION DEFINITION

### Air Augment

The air augment option provides a means for air loading the valve spring housing for automated control. To enable this function a 1/8" FNPT collar is installed on the spring housing and a Teflon seal nut is included to seal the adjusting screw threads to prevent leakage. The 1/8" FNPT port is used as the input fitting for loading the spring housing with instrument air to completely automate or augment manual regulator control. An I/P transducer, or a small, self-relieving air set PRV regulator is required (ordered separately) to regulate the instrument air pressure.

### Panel Mount

The panel mount feature requires a panel cut out of 1-1/2" allowing insertion of the threaded spring housing, and a panel mount ring to secure the regulator against the panel.

## FEATURES & BENEFITS

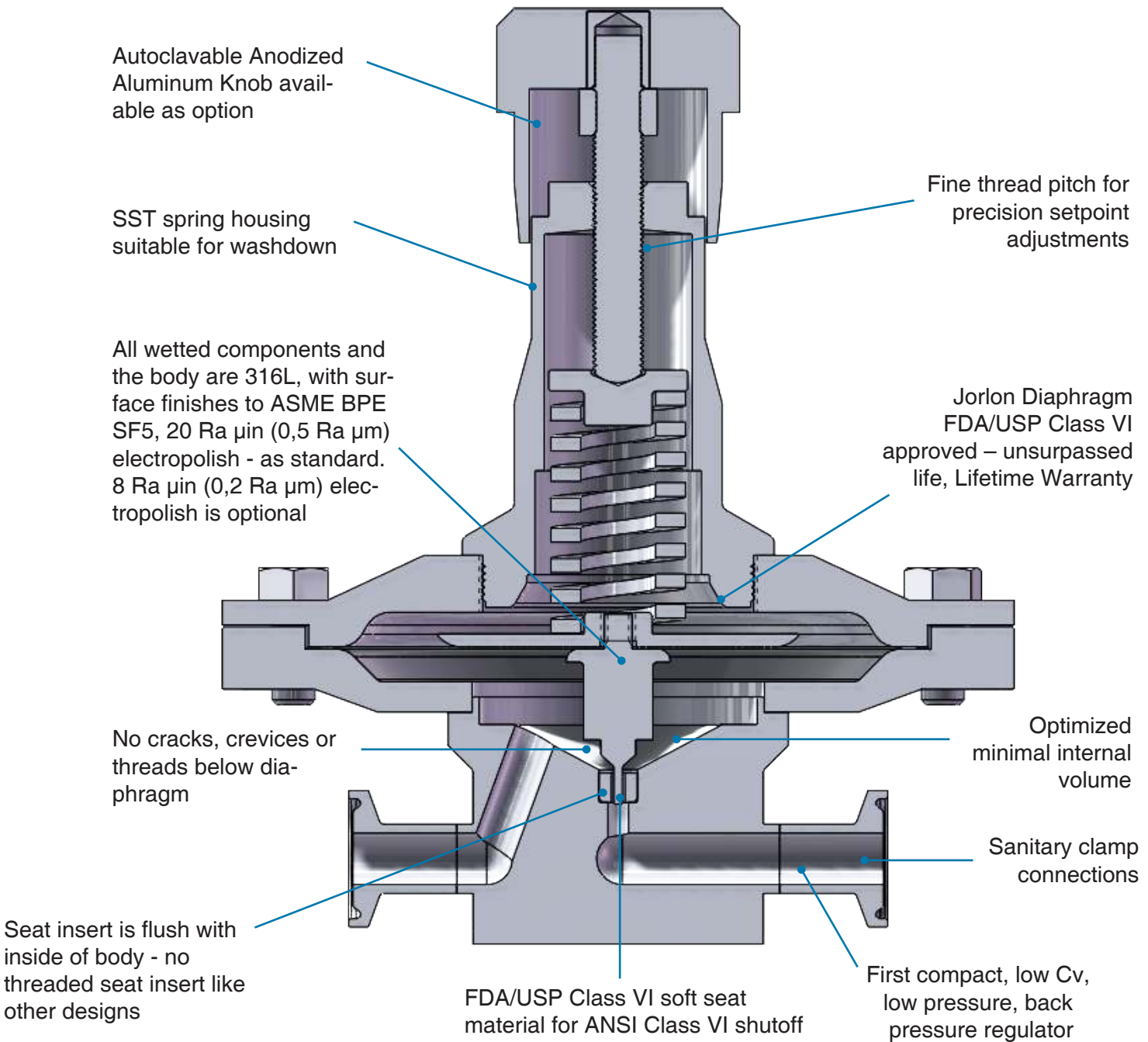

**Note:** The orifice for the JSBLFLP's unique soft seat is machined after insertion in the body during manufacturing. The seat insert cannot be replaced in the field. If repair parts are required, a spare body with insert is recommended, along with standard replacement parts of stem and diaphragm. After the body is replaced, it may be sent back to the factory for seat replacement.

### Sizing Program Instructions:

1. Download the SFCV program. It can be found on our website home page at [www.steriflowvalve.com](http://www.steriflowvalve.com)
2. Use the software to find the appropriate CV for the customer's application conditions.
3. SFCV will tell you the CV needed to pass the required flow. Because the JSBLF works best under 50% capacity, you need to select a CV for the valve that is at least two times larger than the required Cv.

**Example:** Clean compressed air, at ambient temperature,  $P_1 = 45$  psi,  $P_2 = 0$  psi,  $\frac{1}{2}$ " Tri-clamp Connections, flow rate 5 scfm. Using SFCV to size for CV we find that these conditions require an actual CV of 0.15. Calculating for less than 50% capacity we then multiply the result by 2x ( $0.15 \times 2 = 0.30$ ). This means that we should choose the 0.35 CV trim to optimize the valve for the conditions.

### ORIENTATION FOR DRAINABILITY

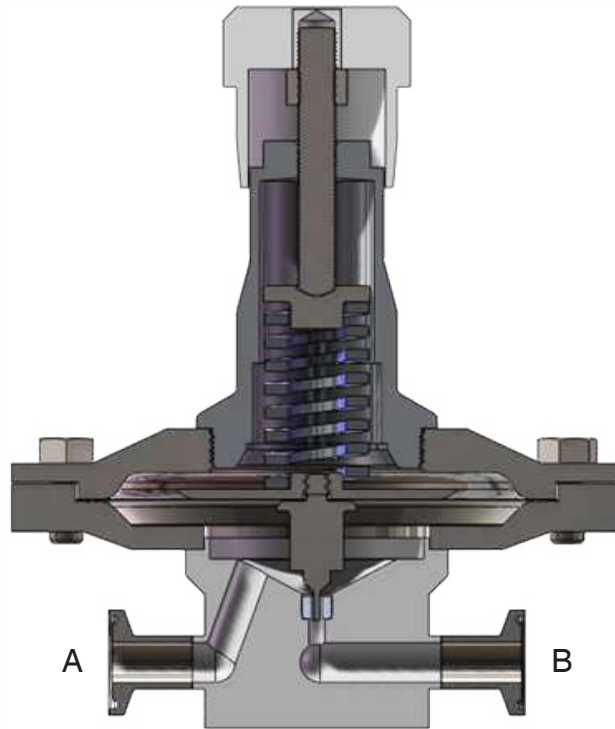

**Horizontal Installation**  
No holdup and drainable out port B with pressure and flow\* when spring force is removed.

**\*Notes**

1. Note: This valve is not recommended for liquid service, as there are areas under the diaphragm that will be difficult to sanitize, and dry. However, if sanitization is required, CIP, rinse liquids, Clean Steam and drying air must flow from A to B in order to open the valve. With spring force (or Air pressure, if AA option) removed, very little pressure is needed to move the diaphragm and plug upward, allowing full velocity flow and drainage out B.

### DIN & ISO TRI-CLAMP DIMENSIONS

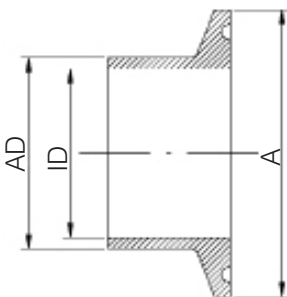

DIN 32676 Row A (DIN 11850)

VALVE SIZE	A	AD	ID
DN15	34.0	19.0	16.0
DN20	34.0	23.0	20.0

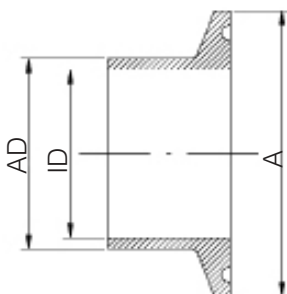

DIN 32676 Row B (ISO 1127)

VALVE SIZE	A	AD	ID
DN15	50.5	21.3	18.1
DN20	50.5	26.9	23.7

## FLOW CONFIGURATIONS

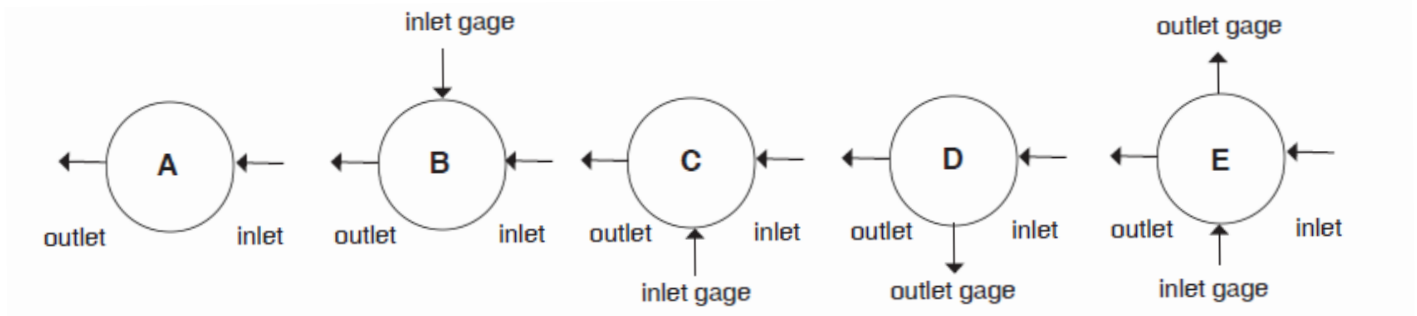

\* Note: Please try to avoid choosing a D-port for a back pressure valve.

\* Gage ports are 1/4" FNPT (consult factory for required alternative)

## DIMENSIONS, IN. (MM)

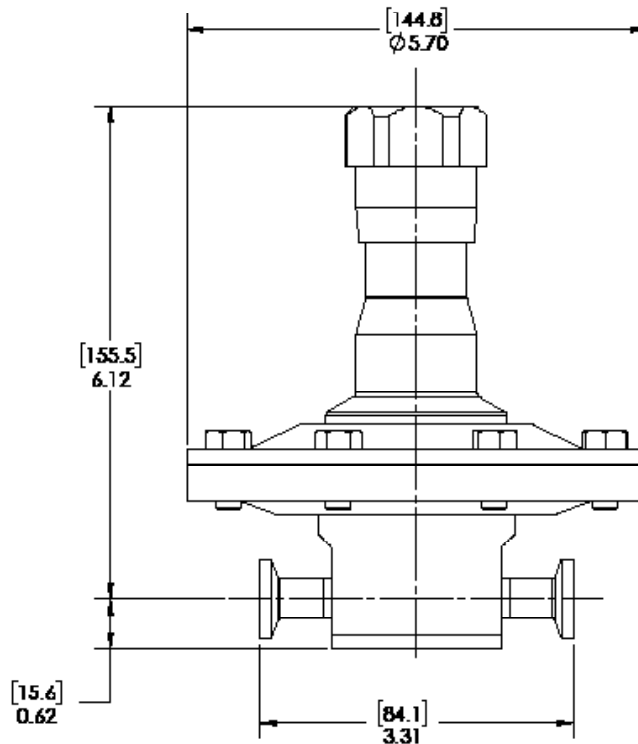

## SAMPLE SPECIFICATIONS

Stainless Steel low flow back pressure regulator shall be made from ASTM A479 barstock material, which includes body and all wetted metal parts, and shall have SF5, 20 Ra  $\mu\text{in}$  (0,5 Ra  $\mu\text{m}$ ) electropolish finish as standard on wetted components. Regulator shall be fully drainable in at least one orientation. Regulator shall be activated by an FDA approved, USP Class VI certified Jorlon diaphragm with Lifetime Warranty. Regulator shall be free of exposed threads and any cracks or crevices within wetted process area. Regulator shall have trim that can be replaced inline by simply unthreading the bonnet and replacing the one piece, diaphragm and trim set. Trim set available in either TFM or PEEK, both FDA and USP Class VI approved.

## JSBLFLP SERIES: COMPACT, HIGH PURITY BIO-PHARMA, LOW FLOW, LOW PRESSURE, BACK PRESSURE REGULATING VALVE

## ORDERING SCHEMATIC

Model	Size	Seat	Material	/	1 & 2	3 & 4	5 & 6	7 & 8	9 & 10	11 & 12	13	14	15
JSBLFLP	-	-		/									

Model	
JSBLFLP	Compact, High Purity Back Pressure Regulator

Size	
038	3/8" (DN10)
050	1/2" (DN15)
075	3/4" (DN20)

Material / End	
6C	316L Tri-Clamp
6P	316L FNPT
6T	316L ASME BPE BWE
6D	316L DIN Tri-Clamp*
6S	316L ISO Tri-Clamp**

\* See DIN 32676 Row A on Page 6

\*\* See DIN 32676 Row B on Page 6

Soft Seat	
T	TFM
P	PEEK

1 & 2	Body Feature	
	End Connection	Port Configuration
1	0.05 Cv	A Port "A"
2	0.15 Cv	B Port "B"
3	0.25 Cv	D Port "D"
4	0.35 Cv	E Port "E"
ZZ	Non-Standard	

3 & 4	Trim
1S	All Cv's
ZZ	Non-Standard

5 & 6	Spring Range
E1	2-15
E2	10-25
E3	15-40
ZZ	Non-Standard

\*These spring ranges can only be selected if valve has NPT connections.

7 & 8	Diaphragm Material
JL	Jorlon
ZZ	Non-Standard

9 & 10	Actuator
SK	Standard Actuator
PM	Panel Mount
AA <sup>1</sup>	Air Augmentation: provides fitting for air input on spring housing, and a stem seat nut
TP	Tamper Proof
ZZ	Non-Standard

<sup>1</sup> See page 2 for complete description

11 & 12	Inlet Gauge*
ØB	0 - 30 PSIG/Bar (Dual)
ØC	0 - 60 PSIG/Bar (Dual)
ØD	0 - 100 PSIG/Bar (Dual)
ØE	0 - 160 PSIG/Bar (Dual)
ØF	0 - 200 PSIG/Bar (Dual)
ØN	None
ZZ	Non-Standard

\* Customer assumes all responsibility for possible damage or injury if selected gauge span does not fully cover range spring / outlet pressure option

13	Outlet Gauge*
B	0 - 30 PSIG/Bar (Dual)
C	0 - 60 PSIG/Bar (Dual)
D	0 - 100 PSIG/Bar (Dual)
E	0-160 PSIG/Bar (Dual)
N	None
ZZ	Non-Standard

\* Customer assumes all responsibility for possible damage or injury if selected gauge span does not fully cover range spring / outlet pressure option

14	SEP Compliance
O	None Required
G	SEP Compliant
Z	Non-Standard

15	Accessories
O	None Required
S	Clean For Oil Free
X	Clean for Oxygen*
J	Clean for Oxygen, Assemble Dry* <sup>1</sup>
Z	Non-Standard

\*Procedure complies with ASTM G-93 2011 and CGA G-4.1-2009

<sup>1</sup>Use of Oxygen safe lubricant (Krytox™ for example) can affect gas line particulate testing. Assembling all wetted components dry (without lubricant) removes that effect, however it may increase the difficulty in disassembly/reassembly of valve seat components during valve maintenance. Note that we will use O2 safe lubricant on non-wetted threaded components.



Steriflow, a division of Jordan Valve

3170 Wasson Road • Cincinnati, OH 45209

513.533.5600 • 800.543.7311 • 513.871.0105 (f)

steriflow@richardsind.com • www.steriflowvalve.com