



# INSTRUCTION MANUAL

Air operated double diaphragm pumps  
Ver. 5.26

Models: DM 15/30  
DM 25/75  
DM 40/125  
DM 50/315  
DM 65/565  
DM 80/850



Serial no.

# DECLARATION OF CONFORMITY

**Directive 2006/42/EC, Annex 2A**

Company: **DELLMECO LTD**

Address: **Unit 1, Willow Row  
Longton, Stoke on Trent  
Staffordshire, ST3 2PU, United Kingdom**

**declares under our sole responsibility, that the product:**

Product name: **Air Operated Double Diaphragm Pumps**

Models: **DM - series**

Referred to in this declaration conforms with the:

**- Directive 2006/42/EC**

Date: **December 2<sup>nd</sup> 2013**

A handwritten signature in black ink, appearing to read 'K. Ziemann', with a stylized flourish at the end.

**K. Ziemann  
Managing Director**

# Table of contents

<b>1. Introduction</b>	<b>4</b>
<b>2. For safe operation</b>	<b>4</b>
<b>3. Warnings and cautions</b>	<b>4</b>
<b>4. Operating caution</b>	<b>4</b>
<b>5. Names of parts and materials</b>	<b>6</b>
5.1. DM 15/30	6
5.2. DM 25/75, DM 40/125	8
5.3. DM 50/315, DM 65/565	10
5.4. DM 80/850	12
<b>6. Assembly</b>	<b>14</b>
<b>7. Installation</b>	<b>14</b>
7.1. Installing the pump	14
7.2. Connecting the ground wire	16
<b>8. Connection</b>	<b>16</b>
8.1. Connecting fluid piping	16
8.2. Connecting air piping	17
<b>9. Operation</b>	<b>18</b>
9.1. Method of operation	18
9.2. Flow adjustment	18
9.3. Shutdown	19
<b>10. Method of cleaning</b>	<b>19</b>
<b>11. Daily check</b>	<b>20</b>
<b>12. Possible problems</b>	<b>20</b>
<b>13. Returning the product for servicing</b>	<b>22</b>
<b>14. Main body specification</b>	<b>24</b>
14.1. Main specification	24
14.2. Appearance and dimensions	24
14.3. Technical Data	25
14.4. Pump code	25
14.5. Performance curves	26
<b>15. Dellmeco Active Pulsation Dampers for Hygienic Pumps</b>	<b>27</b>
15.1. Main specification	27
15.2. Appearance and dimensions of Pulsation Dampers	30
<b>16. Optional Equipment</b>	<b>31</b>
16.1. Barrier Chamber System (option code BC1, BC2, BC3)	31
16.2. Stroke Counting (option code SC1, SC2, SC3, SC5, SC6)	35
16.3. Diaphragm Monitoring (option code DM1, DM2)	37
16.4. Back Flushing System (option code BF1, BF3)	37
16.5. High Pressure (option code HP)	39
16.6. Heating Jacket (option code HJ)	41
16.7. Flap Valve (option code FVF) for Hygienic Series Pumps	42
<b>17. Limited warranty</b>	<b>44</b>

# 1. Introduction

This pump is a positive-displacement pump that transfers fluids by means of diaphragms movement operated by compressed air. The casing in contact with the fluid is made of AISI 316L.

# 2. For safe operation

This document contains information indispensable for maintaining safe and efficient operation of this product. Read this document carefully before using the pump particularly the "warnings and cautions". Get familiar with all operating procedures. This document must be kept handy for future reference.

# 3. Warnings and cautions

The meanings of warning and caution symbols are given below. Be sure to remember their meanings.



## WARNING:

ignoring the caution and operate the product in an improper manner can result in danger of serious bodily injury or death.



## CAUTION:

ignoring the caution and operate the product in an improper manner can result in danger of personal injury or property damage.



This symbol means a "DON'T", and will be followed by an explanation on what you must not do.



This symbol means a "DO", and will be followed by an explanation on what you must do in a specified situation.

# 4. Operating caution

Before using this product



## WARNING



To drive the pump you must use one of the following compressed gases (called in this document "compressed air"):

- Compressed air supplied from air compressor
- Nitrogen (N<sub>2</sub>) gas

Use of compressed air other than the above may cause air pollution, damage to the pump, or even an explosion.



The maximum permissible pressure for the compressed air, and the fluid pumped by one of its pumps is 8 bars.

Should the above applicable maximum permissible pressure be exceeded, the following results may follow: damage to the casing, or even a severe, possibly fatal accident.

In some pump executions, specified by manufacturer, the max. pressure can reach 14 bars.



In case a diaphragm gets damaged, fluid will gush out together with air through the exhaust port. Provide protective measures in consideration of possible leakage of fluid.

When you using the hose and pit etc, make sure to use a model with appropriate corrosion resistance for the fluid to be pumped.



## WARNING

- ! When installing this product, be sure to connect a ground wire from the specified position of this product. Otherwise friction between parts and abrasion caused by the flow of some fluids inside the casing may generate static electricity. Depending on the type of fluid being pumped and the installation environment (such as gases in the air and type of surrounding mixtures), static electricity could cause fire or electric shock.
- ! Some fluid may remain inside the pump and inside the connected piping after shutting down the pump, or if the pump is left unused for a prolonged period. Therefore, be sure to purge the system of fluid and clean the pump before prolonged disuse. The fluid remaining in the connected piping as well as the pump itself may expand because of freezing or heat which may cause damage to the pump or/and piping and lead to leakage of the fluid.
- ∅ Use only genuine Dellmeco parts when replacing component parts of this product.
- ! Torque of all tightening parts must be checked before running the pump. Designated torques is mentioned in maintenance manual.
- ! In case of pumping a hazardous fluid (hot, flammable, strong acid, etc.) with this pump, protective measures (install a pit, a protection box, sensors, etc.) must be provided in consideration of possible leakage of fluid. Warning signs must be displayed at necessary places. Leakage of fluid may cause fire or accident.
- ! Before using this pump, get fully familiar with the precautions regarding the fluid to be pumped, and verify the corrosion resistance of the parts that will come into contact with the fluid. NEVER use the pump with any fluid against which it does not have sufficient corrosion resistance or with a fluid that poses a risk of explosion. If you are unable to verify the corrosion resistance, contact your dealer. Using this product with any fluid against which the parts in contact with the fluid do not have sufficient corrosion resistance may result in damaging the product or leakage of fluid.



## CAUTION

- ! The running pump may generate loud operating noise. Its level will vary depending upon the conditions of use (fluid pumped, supply air pressure and discharge pressure)
- ! To drive this product, supply air with minimum moisture content and without any oil must be used.
- ! If a diaphragm of this pump is damaged, supply air may mix with the fluid or the fluid may flow into the central housing. DO NOT OPERATE THE PUMP if air supply is inadequate or contaminated.
- ∅ While operating this product, do NOT put your hand on the inlet port.

## 5. Names of parts and materials

### 5.1. DM 15/30

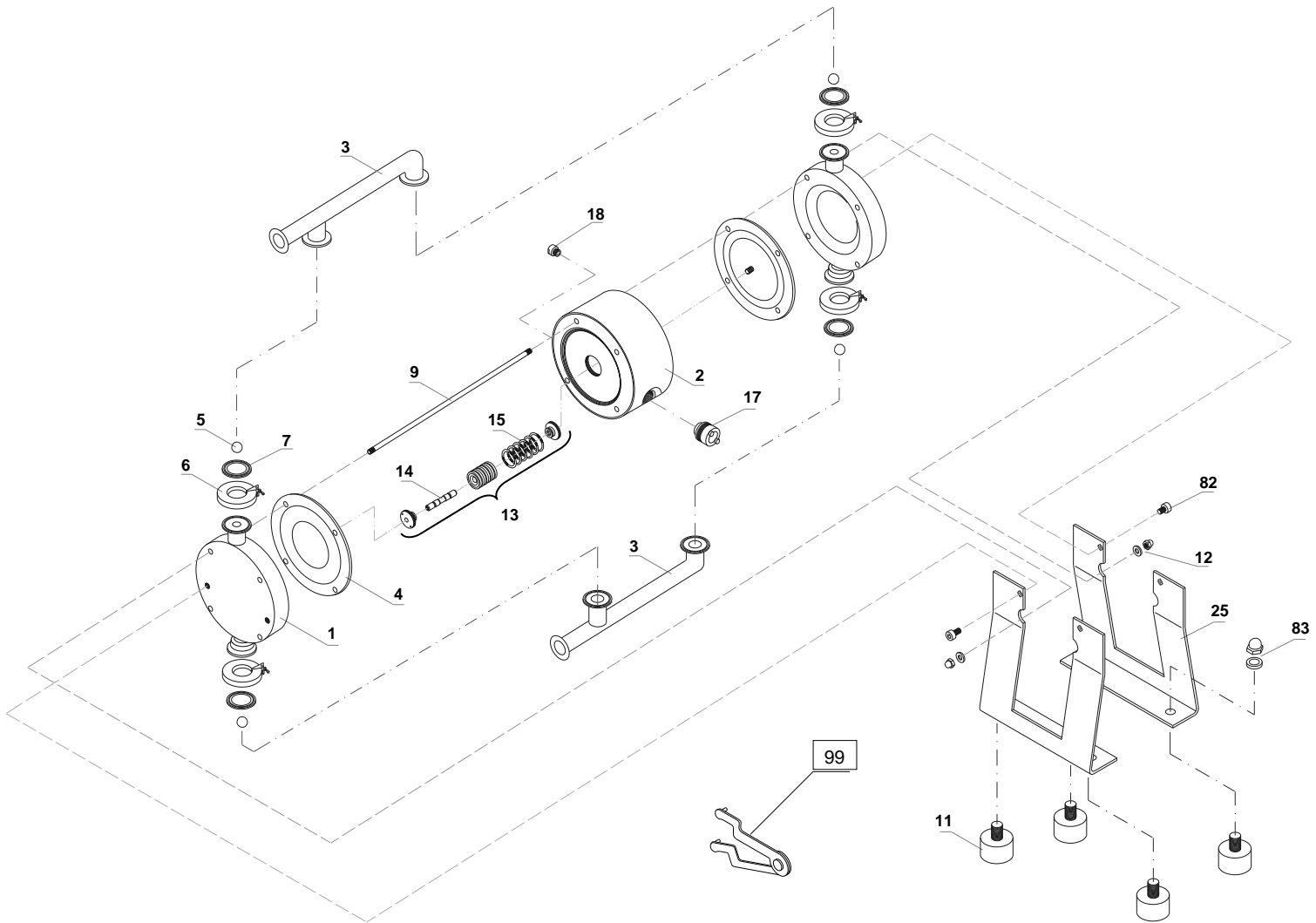

### Spare parts list for DM 15/30 pump

			MATERIAL	DM 15/30
1.	2	Pump housing	AISI 316 L	4 15 01 53
2.	1	Center housing	PE	1 10 10 20
			PE conductive	1 10 10 21
3.	1	Manifold inlet DIN	AISI 316 L	4 15 30 53
		Manifold inlet TC	AISI 316 L	4 15 32 53
		Manifold inlet RJT	AISI 316 L	4 15 37 53
	1	Manifold outlet DIN	AISI 316 L	4 15 33 53
		Manifold outlet TC	AISI 316 L	4 15 35 53
		Manifold outlet RJT	AISI 316 L	4 15 137 53
4.	2	Diaphragm	TFM (PTFE)	1 10 50 05
			EPDM	1 10 50 08
			NBR	1 10 50 10
			EPDM/TFM/PFA	1 10 50 00
5.	4	Valve balls	PTFE	1 15 60 23
			EPDM	1 15 60 08
			NBR	1 15 60 10
			AISI 316	1 15 60 52
			Polyurethane	1 15 60 07
			Ceramic	1 15 60 90
6.	4	Clamp	AISI 304	4 25 36 50
7.	4	Sealing	PTFE	4 15 70 23
			EPDM	4 15 70 08
			Silicone	4 15 70 11
			NBR	4 15 70 10
			FPM	4 15 70 09
9.	4	Housing bolt	AISI 304	4 15 42 50
11.	4	Shock absorber	NR/SS	1 15 69 52
12.	8	Nut with washer	AISI 304	1 10 45 50
13.	1	Air valve	PET/NBR	1 08 020 31
			PET/FPM	1 08 020 32
14.	1	Shaft	AISI 304	1 08 24 50
15.	6	O-ring	NBR	1 08 080 10
			FPM	1 08 080 09
17.	1	Muffler	PE porous	1 08 99 35
			PE porous	1 08 499 35
			BZ	1 08 99 86
			BZ	1 08 499 86
18.	1	Air adapter	PP	1 08 46 28
20.	1	Tube	PP	4 15 96 28
			AISI 316 L	4 15 96 53
25.	1	Support	AISI 304	4 15 96 50
35.	1	Center housing complete	PE	1 10 11 20
			PE conductive	1 10 11 21
82.	4	Support nut	AISI 304	4 15 138 50
83.	4	Shock absorber nut with washer	AISI 304	4 15 345 50
99.	1	Air valve key (SK4)	diverse	1 08 58 00

## 5.2. DM 25/75, DM 40/125

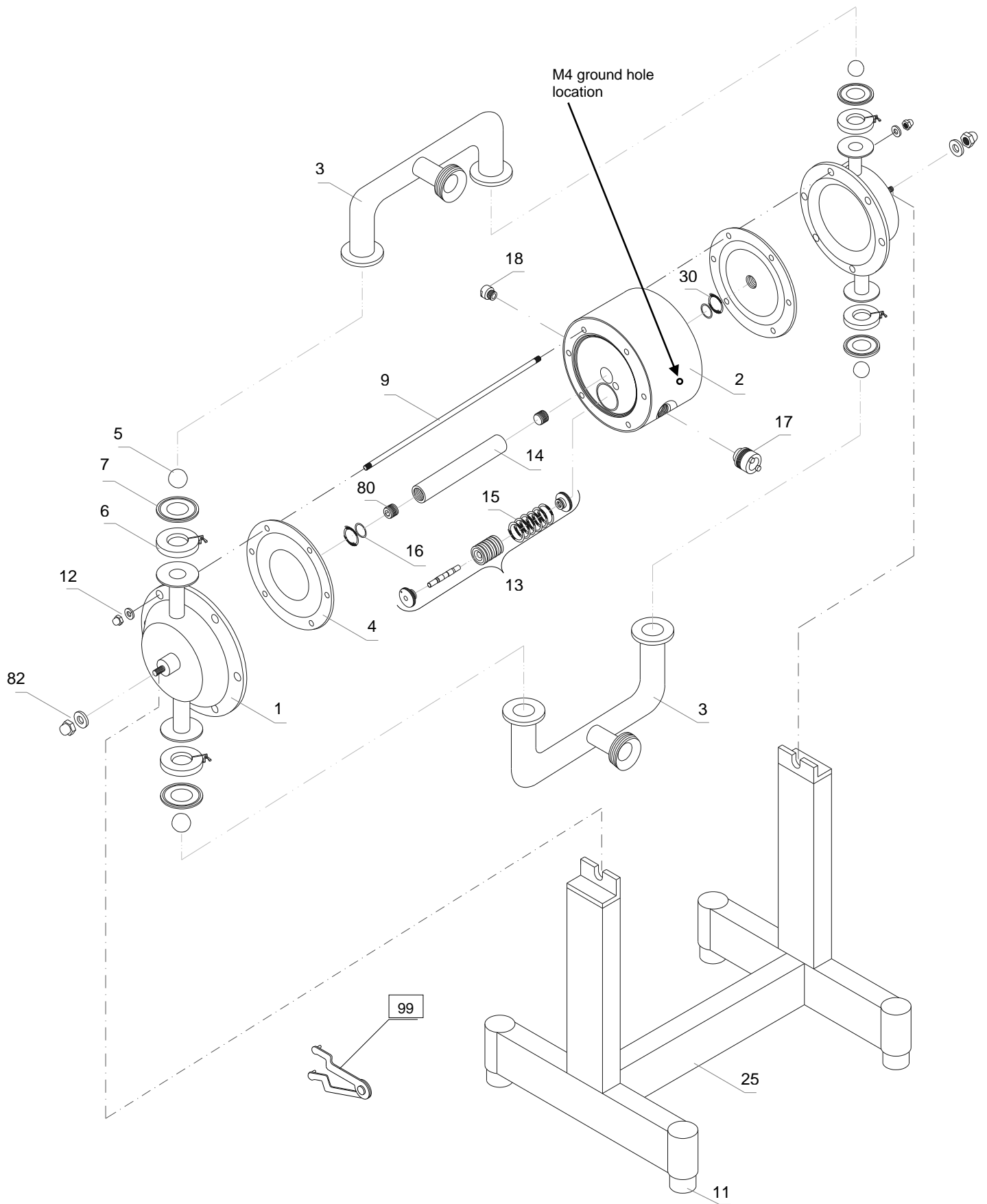



### Spare parts list for DM 25/75 and DM 40/125 pumps

			<b>MATERIAL</b>	<b>DM 25/75</b>	<b>DM 40/125</b>
1.	2	Pump housing	AISI 316 L	4 25 01 53	4 40 01 53
2.	1	Center housing	PE	1 15 10 20	1 25 10 20
			PE conductive	1 15 10 21	1 25 10 21
3.	2	Manifold inlet DIN	AISI 316 L	4 25 30 53	4 40 30 53
		Manifold inlet SMS	AISI 316 L	4 25 31 53	4 40 31 53
		Manifold inlet TC	AISI 316 L	4 25 32 53	4 40 32 53
		Manifold inlet RJT	AISI 316 L	4 25 37 53	4 40 37 53
		Manifold outlet DIN	AISI 316 L	4 25 33 53	4 40 33 53
		Manifold outlet SMS	AISI 316 L	4 25 34 53	4 40 34 53
		Manifold outlet TC	AISI 316 L	4 25 35 53	4 40 35 53
		Manifold outlet RJT	AISI 316 L	4 25 137 53	4 40 137 53
4.	2	Diaphragm	TFM (PTFE)	1 15 50 05	1 25 50 05
			EPDM	1 15 50 08	1 25 50 08
			NBR	1 15 50 10	1 25 50 10
			EPDM/TFM/PFA	1 15 50 00	-
5.	4	Valve balls	PTFE	1 15 60 23	1 25 60 23
			EPDM	1 15 60 08	1 25 60 08
			NBR	1 15 60 10	1 25 60 10
			AISI 316	1 15 60 52	1 25 60 52
			Polyurethane	1 15 60 07	1 25 60 07
			Ceramic	1 15 60 90	1 25 60 90
6.	4	Clamp	AISI 304	4 25 36 50	4 40 36 50
7.	4	Sealing	PTFE	4 25 70 23	4 40 70 23
			EPDM	4 25 70 08	4 40 70 08
			Silicone	4 25 70 11	4 40 70 11
			NBR	4 25 70 10	4 40 70 10
			FPM	4 25 70 09	4 40 70 09
9.	6	Housing bolt	AISI 304	4 25 42 50	4 40 42 50
11.	4	Shock absorber	NR/SS	1 15 69 52	1 15 69 52
12.	12	Nut with washer	AISI 304	1 15 45 50	1 25 45 50
13.	1	Air valve	PET/NBR	1 15 020 31	1 15 020 31
			PET/FPM	1 15 020 32	1 15 020 32
14.	1	Shaft	AISI 304	1 15 40 50	1 25 40 50
15.	6	O-ring	NBR	1 15 080 10	1 15 080 10
			FPM	1 15 080 09	1 15 080 09
16.	2	Center housing seal	PE	1 15 85 22	1 25 85 22
17.	1	Muffler	PE porous	1 15 99 35	1 15 99 35
			PE porous	1 15 499 35	1 15 499 35
			BZ	1 15 99 86	1 15 99 86
			BZ	1 15 499 86	1 15 499 86
18.	1	Air adapter	PP	1 15 46 28	1 15 46 28
20.	1	Tube	PP	4 25 96 28	4 40 96 28
			AISI 316 L	4 25 96 53	4 40 96 53
25.	1	Support	AISI 304	4 25 96 50	4 40 96 50
30.	2	O-ring for center housing seal	NBR	1 15 85 10	1 25 85 10
35.	1	Center housing complete	PE	1 15 11 20	1 25 11 20
			PE conductive	1 15 11 21	1 25 11 21
80.	2	Shaft allen pin screw	AISI 304	1 15 540 50	1 25 540 50
82.	4	Support nut	AISI 304	4 25 138 50	4 40 138 50
99.	1	Air valve key (SK4)	diverse	1 08 58 00	1 08 58 00

### 5.3. DM 50/315, DM 65/565

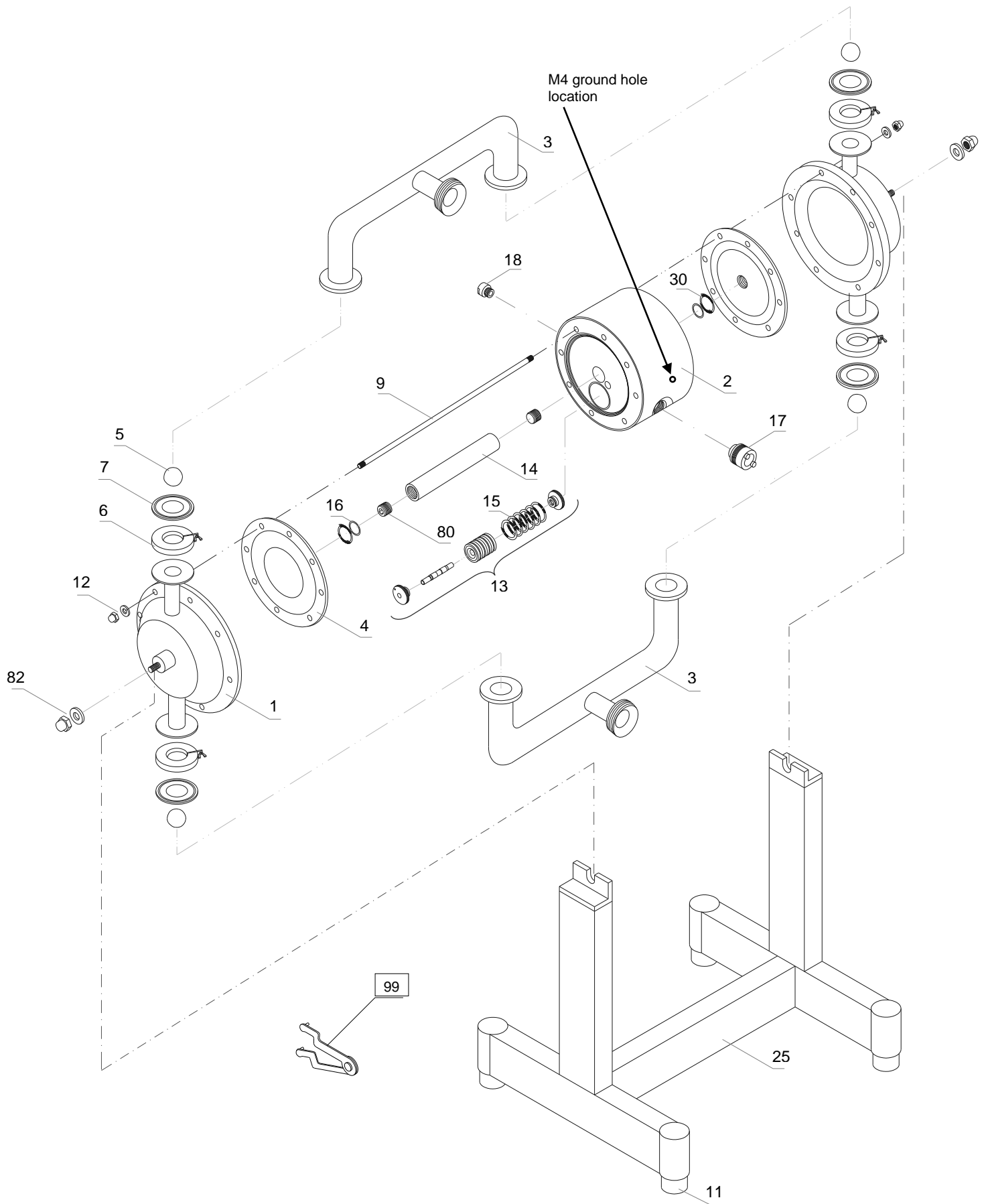

### Spare parts list for DM 50/315 and 65/565 pumps

			MATERIAL	DM 50/315	DM 65/565
1.	2	Pump housing	AISI 316 L	4 50 01 53	4 65 01 53
2.	1	Center housing	PE	1 40 10 20	1 50 10 20
			PE conductive	1 40 10 21	1 50 10 21
3.	2	Manifold inlet DIN	AISI 316 L	4 50 30 53	4 65 30 53
		Manifold inlet SMS	AISI 316 L	4 50 31 53	4 65 31 53
		Manifold inlet TC	AISI 316 L	4 50 32 53	4 65 32 53
		Manifold inlet RJT	AISI 316 L	4 50 37 53	4 50 37 53
		Manifold outlet DIN	AISI 316 L	4 50 33 53	4 65 33 53
		Manifold outlet SMS	AISI 316 L	4 50 34 53	4 65 34 53
		Manifold outlet TC	AISI 316 L	4 50 35 53	4 65 35 53
		Manifold outlet RJT	AISI 316 L	4 50 137 53	4 50 137 53
4.	2	Diaphragm	TFM (PTFE)	1 40 50 05	1 50 50 05
			EPDM	1 40 50 08	1 50 50 08
			NBR	1 40 50 10	1 50 50 10
5.	4	Valve balls	PTFE	1 40 60 23	1 50 60 23
			EPDM	1 40 60 08	1 50 60 08
			NBR	1 40 60 10	1 50 60 10
			AISI 316	1 40 60 52	1 50 60 52
			Polyurethane	1 40 60 07	1 50 60 07
6.	4	Clamp	AISI 304	4 50 36 50	4 65 36 50
7.	4	Sealing	PTFE	4 50 70 23	4 65 70 23
			EPDM	4 50 70 08	4 65 70 08
			Silicone	4 50 70 11	4 65 70 11
			NBR	4 50 70 10	4 65 70 10
			FPM	4 50 70 09	4 65 70 09
9.	8	Housing bolt	AISI 304	4 50 42 50	4 65 42 50
11.	4	Shock absorber	NR/SS	1 15 69 52	1 15 69 52
12.	16	Nut with washer	AISI 304	1 40 45 50	1 50 45 50
13.	1	Air valve	PET/NBR	1 40 020 31	1 40 020 31
			PET/FPM	1 40 020 32	1 40 020 32
14.	1	Shaft	AISI 304	1 40 40 50	1 50 40 50
15.	6	O-ring	NBR	1 40 87 10	1 40 87 10
			FPM	1 40 87 09	1 40 87 09
16.	2	Center housing seal	PE	1 40 85 22	1 50 85 22
17.	1	Muffler	PE porous	1 40 99 35	1 50 99 35
			PE porous	1 40 499 35	1 50 499 35
			BZ	1 40 99 86	1 50 99 86
			BZ	1 40 499 86	1 50 499 86
18.	1	Air adapter	PP	1 40 46 28	1 40 46 28
25.	1	Support	AISI 304	4 50 96 50	4 65 96 50
30.	2	O-ring for center housing seal	NBR	1 40 85 10	1 50 85 10
35.	1	Center housing complete	PE	1 40 11 20	1 50 11 20
			PE conductive	1 40 11 21	1 50 11 21
80.	2	Shaft allen pin screw	AISI 304	1 40 540 50	1 50 540 50
82.	4	Support nut	AISI 304	4 50 138 50	4 65 138 50
99.	1	Air valve key (SK4)	diverse	1 08 58 00	1 08 58 00

### 5.4. DM 80/850

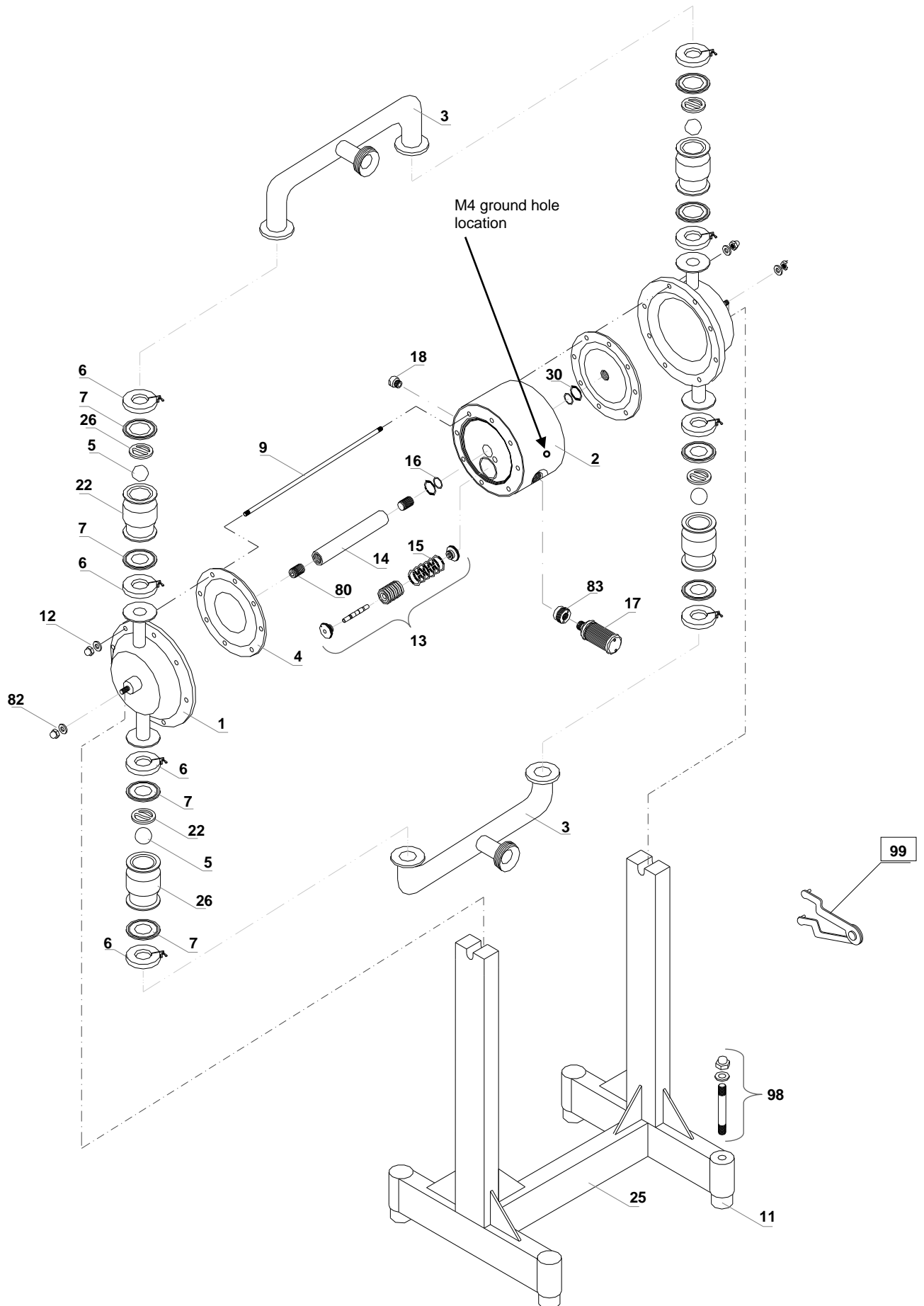

### Spare parts list for DM 80/850 pump

			MATERIAL	DM 80/850
1.	2	Pump housing	AISI 316 L	4 80 01 53
2.	1	Center housing	PE	1 80 10 20
			PE conductive	1 80 10 21
3.	2	Manifold inlet/outlet DIN	AISI 316 L	4 80 30 53
		Manifold inlet/outlet SMS	AISI 316 L	4 80 31 53
		Manifold inlet/outlet TC	AISI 316 L	4 80 32 53
		Manifold inlet/outlet RJT	AISI 316 L	4 80 37 53
4.	2	Diaphragm	TFM (PTFE)	1 80 50 05
			EPDM	1 80 50 08
			NBR	1 80 50 10
5.	4	Valve balls	PTFE	1 80 160 23
			EPDM	1 80 160 08
			NBR	1 80 160 10
6.	8	Clamp	AISI 304	4 80 36 50
7.	8	Sealing	PTFE	4 80 70 23
			EPDM	4 80 70 08
			Silicone	4 80 70 11
			NBR	4 80 70 10
			FPM	4 80 70 09
9.	8	Housing bolt	AISI 304	4 80 42 50
11.	4	Shock absorber	AISI 316L	1 80 69 53*
12.	16	Nut with washer	AISI 304	1 80 45 50
13.	1	Air valve	PET/NBR	1 80 020 31
			PET/FPM	1 80 020 32
14.	1	Shaft	AISI 304	1 80 40 50
15.	6	O-ring	NBR	1 80 87 10
			FPM	1 80 87 09
16.	2	Center housing seal	PE	1 80 85 22
17.	1	Muffler	diverse	1 80 99 00
18.	1	Air adapter	PP	1 80 46 28
22.	4	Valve seat	AISI 316L	4 80 54 53
25.	1	Support	AISI 304	4 80 96 50
26.	4	Valve stopper	AISI 316L	4 80 39 53
30.	2	O-ring for center housing seal	NBR	1 80 85 10
35.	1	Center housing complete	PE	1 80 11 20
			PE conductive	1 80 11 21
80.	2	Shaft allen pin screw	AISI 304	1 80 540 50
82.	2	Support nut with washer	AISI 304	1 80 45 50
83.	1	Muffler adapter	PE	1 80 299 20
			PE conductive	1 80 299 21
98.	4	Absorber bolt with nut and washer	AISI 304	1 80 945 50**
99.	1	Air valve key (SK4)	diverse	1 80 58 00

\* - Part 1 80 69 53 not available with Trolley (Pump with T Option)

\*\* - Part 1 80 945 50 available only with Trolley option

## 6. Assembly



### CAUTION



When installing accessories prevent any foreign matter from getting into the product. Otherwise malfunction of the air-valve may follow.

## 7. Installation

### 7.1. Installing the pump

1) Decide where the pump is to be installed and secure a site.

Note:

- The suction lift should be kept as short as possible.
- Sufficient space around the pump for maintenance must be provided.

When fixing the pump in place, use the cushions on the pump base. The tied-down bolts should be tightened a little at a time to secure the pump.

### SELF PRIMING APPLICATION

Suction lift capability may vary depending on the construction materials and application parameters. The range is from 5 meters dry to 9 meters in a primed condition (values calculated for pumping water at 20 degrees Celsius).

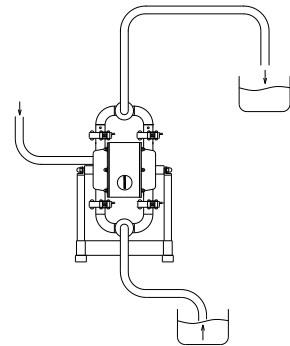

### SUBMERGED OPERATION

All pumps may operate in full submersion. Construction materials must be compatible with surrounding liquid and the air exhaust must be placed above the liquid level.

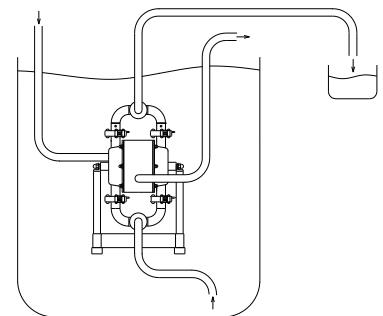

### POSITIVE SUCTION HEAD

Common as a method of drawing off the bottoms of holding tanks and clarifiers. Optimum inlet pressure should be kept at 0.2-0.3 bar.

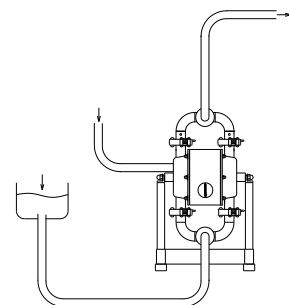



## CAUTION

- ! Vibration generated by pump operation should be absorbed. Take it into consideration when mounting it.
- ! When using the pump in submerged position, follow the steps below:
  - Verify the corrosion resistance of each component of the pump. DO NOT expose the pump to any fluid for which it does not have proper corrosion resistance.
  - Exhaust should direct outside, not into the fluid in which the pump is submerged.
- ! The running pump may generate noise. Its level will depend upon conditions of use (kind of fluid being pumped, supply air pressure and discharge pressure).



## WARNING

- ! The end of the hose must be equipped with a pit, a protection box, etc. at the end of the hose in case the diaphragm gets damaged and a leakage of the fluid follows.
- ! Pump exhaust should be directed to a safe place, away from people, animals and food.



## CAUTION

- ! Before putting the pump into operation as well as after some hours of pumping, the housing bolts have to be fixed according to the torque data of the following schedule, as the elements of construction “settle”. Fixing the bolts is necessary as well after longer periods of stoppage, at extreme temperature variations, after transport and dismantling the pump.

Size	DM 15/30	DM 25/75	DM 40/125	DM 50/315	DM 65/565	DM 80/850
Torque values for housing bolts [Nm]:	9	10	14	17	22	45

## 7.2. Connecting the ground wire

- a) When installing the conductive pump, be sure to connect the ground wire at the specified position.
- b) Ground wires should be connected to peripheral equipment and piping as well.
- c) Use 2.0 mm<sup>2</sup> minimum ground wire.



## WARNING



Ground wires must be connected to the piping and any other peripheral equipment. When operating the pump make sure it is properly grounded. Otherwise friction between the parts and abrasion caused by some fluids flowing inside the casing may generate static electricity. In addition it may cause fire or electric shock, depending on the type of fluid being pumped and the installation environment (such as gases in the air or the surrounding mixtures).

## 8. Connection

### 8.1. Connecting fluid piping

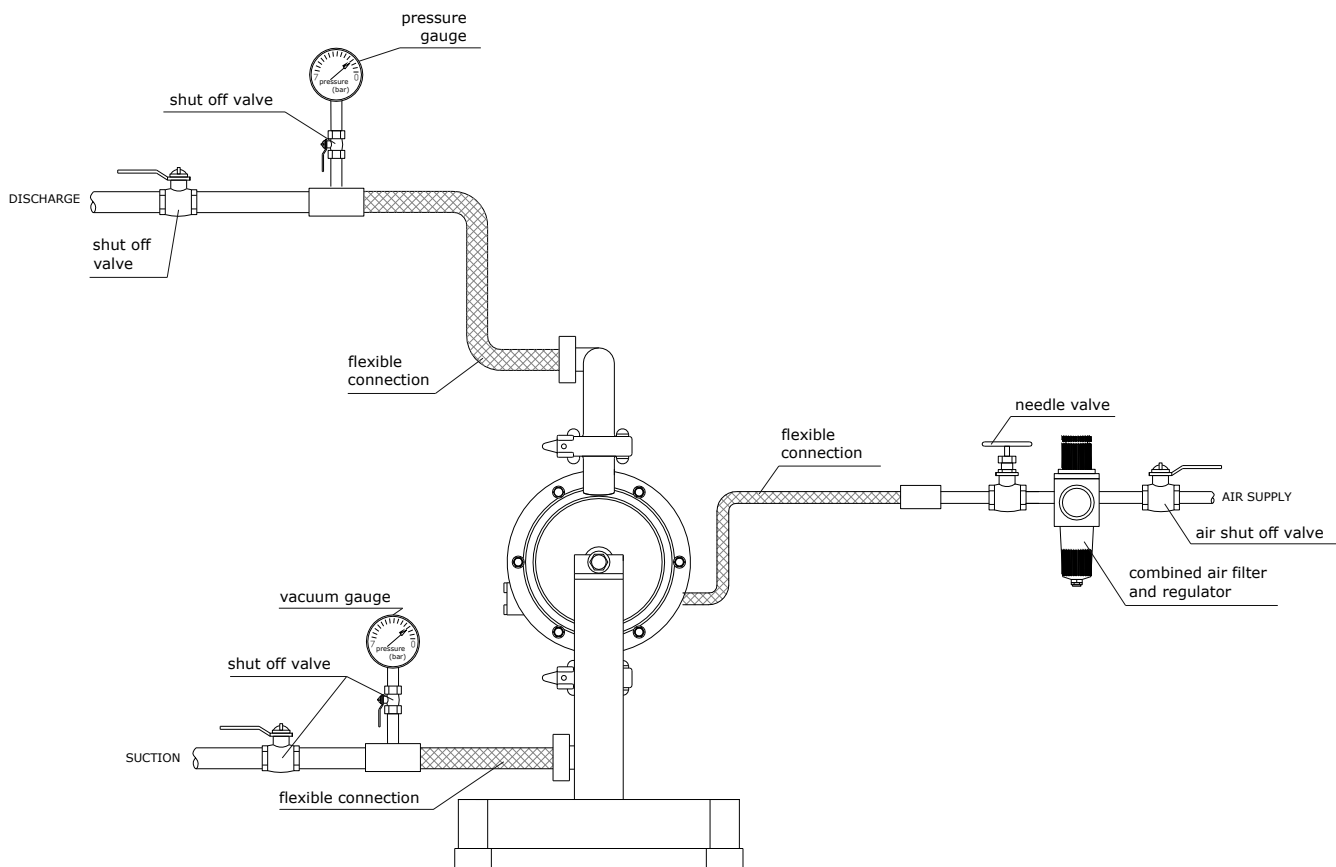

- 1) Connect a flow valve and a drain valve to the fluid discharge port of the pump.
- 2) Connect a valve for maintenance to the fluid suction intake port of the pump.
- 3) Connect a hose to the valve on the suction-port side and the valve of the discharge-port side of the pump.
- 4) Connect a hose on the suction-side intake and the discharge-port side to the respective vessels.





## CAUTION

- ! A hose must be flexible to absorb pump vibration. The hose must be grounded.
- ! There must be NO external force on any connection part of the pump. Be especially careful not to have the pump support part of the weight of the hose and the piping.
- ! Use a sturdy hose that will not collapse under the strong suction of the pump. The hose must be of more than sufficient pressure rating.
- ! Use a hose of a diameter the same as or larger than the pump's ports. If the diameter of a hose is smaller, it will affect the pump's performance or cause its malfunction.
- ! Keep a vessel below the relief valve to catch any drain off.
- ! The product has been inspected using clean water at 8 bar discharge pressure.

### 8.2. Connecting air piping



## WARNING

- ! Before starting work, make sure that the air compressor is shut off.

- 1) Connect air valve, air filter, regulator to a hose connected to the compressor. Install items near the pump.
- 2) Connect the hose from the peripheral equipment to the air valve of the pump's supply port.

**Note:**

The diameter of the piping should be the same as the diameter of the pump supply port in order to supply sufficient air. Peripheral equipment with sufficient airflow should be chosen to meet the requirement of the pump air consumption. It must be installed nearest the pump unit, even using dry air. Usage and stability of air pressure must be considered.

## 9. Operation

### 9.1. Method of operation



#### CAUTION

- ! Before starting the pump, check that all piping is properly connected.
- ! Before starting the pump, check that **all the bolts are securely tightened**.
- ! Check that the regulator and the drain valve on the discharge side are closed and that the valve on the suction side is opened.

- 1) Start the air compressor.
- 2) Open the air valve. Using a regulator adjust the supply air pressure to within the permissible range.
- 3) Open the flow valve on the discharge side.
- 4) First, check that fluid is flowing inside the piping and is being pumped to the discharge side, and then fully open the air valve.



#### CAUTION

- ∅ Do NOT open the air valve suddenly.

### 9.2. Flow adjustment

Adjust the flow valve on the discharge side, or adjust the supply air pressure.



#### CAUTION

- ! The supply air pressure may initially rise during closing the flow valve. Make sure that the pressure is kept within the normal operating range.
- ! The permissible suction flow speed can vary depending upon the viscosity and specific gravity of the fluid, the suction stroke and other factors. However in case of a rapid growth of the pump speed (flow speed of fluid), cavitation will occur. This will reduce pump performance and may cause a malfunction. In order to prevent cavitations, adjust the supply air pressure and the flow.
- ! If fluid is not discharged after you start the pump, or if you hear an abnormal noise or notice any irregularity, shut down the pump immediately.

### 9.3. Shutdown

Close the air valve of the pump and shut off the supply air.



#### CAUTION

- ! When the pump is shut down while pumping slurry, particulate matter contained in the slurry will be deposited and get stuck inside the out chamber. Therefore after finishing work the pump must be purged of the remaining fluid. Otherwise when starting the pump again, the diaphragm may yet damaged and the centre rod may bend.



#### CAUTION

- ! Keep a vessel below the relief valve for any drain off.
- ! Be careful! - Fluid under pressure will gush out the moment you open the valve.
- ! If the pump is unused for a prolonged period, purge and clean it.

## 10. Method of cleaning



#### WARNING

- ! Make sure that compressed air is not supplied to the pump BEFORE you start cleaning the pump.
- ! Make sure that the pump is not pressurized BEFORE you start cleaning the pump.

- 1) Remove the hose from the suction side of the pump.
- 2) Close the flow valve on the discharge side and open the drain valve. Then start air pressure for a while to discharge possibly much fluid remaining inside the pump.
- 3) Remove the hose from the discharge side, and attach different hoses to the suction side and the discharge side for cleaning.
- 4) Be ready with a vessel with cleaning solution, the kind appropriate for the type of fluid pumped. Next connect the suction-side and the discharge-side hoses of the pump.
- 5) Start the pump air pressure slowly, and let the cleaning solution circulate for sufficient cleaning.
- 6) Flush with clean water.
- 7) Remove the hose from the suction side of the pump, run the pump for a while to purge the pump of remaining fluid as much as possible.



#### CAUTION



Be extremely careful when removing piping - the fluid will gush out.



After cleaning with clean water, turn the pump upside-down to let the water flow out.

## 11. Daily check

Before starting pump operation, conduct the following check procedures every day. In case there appears any irregularity, do NOT start running the pump until the cause of the irregularity has been determined and corrective measures have been taken.

- a) Make sure that there is no leakage of fluid from any connection part or the pump.
- b) Make sure that there are no cracks in the pump casing or piping.
- c) Check the tightness of every bolt of the pump.
- d) Make sure that the connection parts of the piping and peripheral equipment are not loose.
- e) Make sure that any parts of the pump that are to be replaced at regular intervals have been changed.

## 12. Possible problems

### 12.1. Pump does not run

Cause	Action to take
The exhaust port (muffler) of pump is clogged with sludge.	Check and clean the exhaust port and muffler.
Air is not supplied.	Start the compressor, and open the air valve and air regulator.
The supply air pressure is low.	Check the compressor and the configuration of air piping.
Air leaks from connection parts.	Check the connection parts and tightness of bolts.
The flow valve on the discharge side is not open.	Open the flow valve on the discharge side.
The fluid piping is clogged with sludge.	Check and clean the fluid piping.
The pump is clogged with sludge.	Disassemble the casing, check and clean.

### 12.2. Pump runs, but fluid does not come out

Cause	Action to take
The suction lift or discharge head is long.	Confirm the piping configuration and shorten the length.
The discharge-side fluid piping (including the strainer) is clogged with sludge.	Check and clean the fluid piping.
The valve on the suction side is not open.	Open the valve on the suction side.
The pump is clogged with sludge.	Disassemble the casing, check and clean.
The balls and valve seats are worn out or damaged.	Disassemble the pump, check and replace parts.

### 12.3. Flow (discharge volume) decreased

Cause	Action to take
The supply air pressure is low.	Check the compressor and configuration of air piping.
Air piping or peripheral equipment is clogged with sludge.	Check and clean the air piping.
The discharge-side flow valve opens differently.	Adjust the discharge-side flow valve.
Air is taken in together with fluid.	Replenish fluid and check the configuration of the suction-side piping.
Cavitations occur.	Adjust the supply air pressure and discharge pressure, and shorten the suction lift.
Chattering occurs.	Adjust the supply air pressure and discharge pressure. Reduce inlet flow valve to adjusting liquid pressure and volume.
The fluid piping (including the strainer) is clogged with sludge.	Check and clean the fluid piping and strainer.
The exhaust port (muffler) of the pump is clogged with sludge.	Check and clean the exhaust port and muffler.
The pump is clogged with sludge.	Disassemble the casing, check and clean.

### 12.4. Liquid leakage from exhaust port (silencer)

Cause	Action to take
Damaged diaphragms.	Replace the diaphragms.

### 12.5. High air consumption during operation

Cause	Action to take
The o-rings and sleeves are worn out.	Disassemble the air-valve, check and clean. Replace parts as necessary.

### 12.6. Irregular noise

Cause	Action to take
The supply air pressure too high.	Adjust the supply air pressure.
The pump is clogged with sludge with particles of larger than the permissible diameter.	Disassemble the casing, check and clean.

### 12.7. Irregular vibration

Cause	Action to take
The supply air pressure too high.	Adjust the supply air pressure.
The sleeves are worn out.	Disassemble the air-valve, check and clean. Replace parts as necessary.
Connection parts and pump mounting are loose.	Check each connection part and tighten the bolts.

If any of the above mentioned causes do not apply to your problem, contact your dealer or our office.

## 13. Returning the product for servicing

If you want to return the product for servicing, copy the **Trouble-Reporting FAX Sheet**, fill it out giving the details of the problem and conditions of operation, and fax it to your dealer or our regional office.

- 1) Get an acceptance from your dealer or regional office.
- 2) Clean the pump.
- 3) Return the product in the same package as when it was first shipped from the factory.





## WARNING



It is the end-user responsibility to thoroughly wash and clean the pump to prevent any damages caused by accidental liquid leaks.



## CAUTION



Be sure to maintain the transport safety by preventing any liquid leaks from the pump.

## 14. Main body specification

### 14.1. Main specification



## CAUTION



Due to constant improvements and/or modifications to our products, the dimensions and detailed technical specifications may be changed without prior information. Any claims concerning these changes shall not be considered. Please contact your dealer or our regional office for details.

### 14.2. Appearance and dimensions

DM 15/30 H..

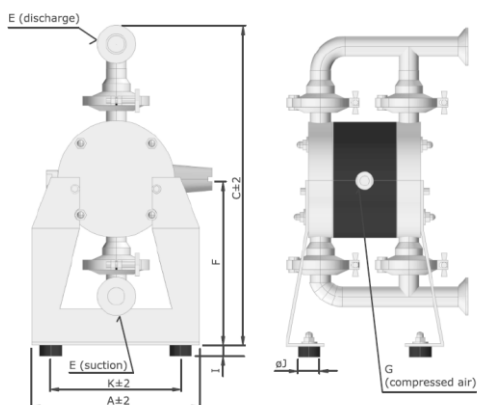

DM 25/75 H., ..., DM 80/850 H..

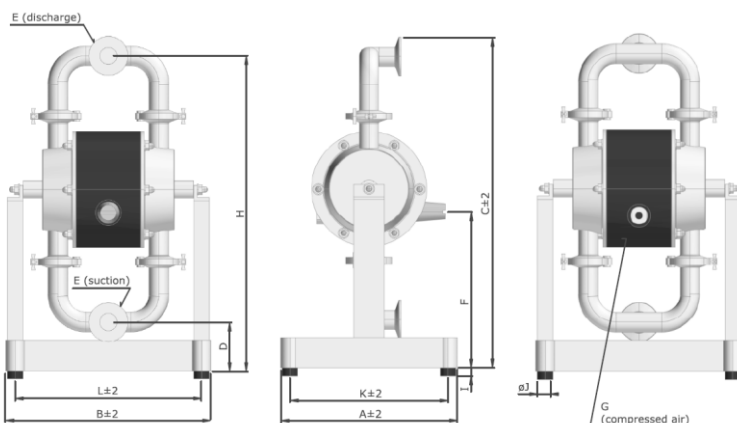

	A	B	C	D	E			F	G	H	I	øJ	K	L
					TC	DN	SMS							
DM 15/30	150	165	299	46	1/2"	15	-	162	R 1/8"	282	18	30	116	103
DM 25/75	206	240	230	75	1"	25	25	204	R 1/4"	394	18	30	206	238
DM 40/125	256	287	465	67	1 1/2"	40	38	221	R 1/4"	440	18	30	226	257
DM 50/315	350	387	679	102	2"	50	51	247	R 1/2"	640	18	30	325	357
DM 65/565	350	459	888	126	2 1/2"	65	64	357	R 1/2"	842	18	30	326	435
DM 80/850	590	600	1310	129	3"	80	90	688	R 3/4"	1257	18	30	565	575



### 14.3. Technical Data

	15/30	25/75	40/125	50/315	65/565	80/850
Max capacity (l/min)	30	75	125	315	565	850
Max pressure (bar)	8					
Nominal port size (DIN 11851 standard)	DN 15	DN 25	DN 40	DN 50	DN 65	DN 80
Optional connections	Tri-Clamp, SMS, RJT					
Air connection	R ¼"	R ¼"	R ¼"	R ½"	R ½"	R ¾"
Maximum suction lift dry (mWC):	1.5	1.5	4.0	4.0	5.0	5.0
Maximum suction lift wet (mWC)	9.0					
Max diameter solids (mm)	4	5	8	11	14	15
Temperature limits - NBR, EPDM (°C)	80					
Temperature limits - PTFE (°C)	120					
Weight (kg)	5	8	11	26	34	85
Material of pump housing	AISI 316L					
Material of center housing	PE, PE conductive					
Diaphragm options	NBR, EPDM, TFM/PTFE					
Valve balls	NBR, EPDM, PTFE, AISI 316					
Gaskets	Silicone, PTFE, EPDM, NBR, FPM					

The above figures represent EPDM-fitted pump capabilities.  
It can vary for PTFE-fitted diaphragm.

### 14.4. Pump code

<p><b>DM 25/75 HTS-TC- DM1</b></p>	<p><b>DM 1 - Optional equipment:</b></p> <p><b>BC 1</b> – Barrier chamber with sensors (Namur)  <b>BC 2</b> – Barrier chamber as BC1 with controllers  <b>BC 3</b> – Barrier chamber as BC2, ATEX</p> <p><b>DM 1</b> – Diaphragm monitoring, Namur - ATEX  <b>DM 2</b> – Diaphragm monitoring with controller</p> <p><b>SC 1</b> – Stroke sensor, ATEX  <b>SC 2</b> – SC1 plus stroke counter  <b>SC 3</b> – SC1 plus stroke counter – ATEX  <b>SC 5</b> – Stroke counting pneumatic with pressure transmitter  <b>SC 6</b> – SC 5 plus stroke counter</p> <p><b>AF1, AF2</b> – Air filter, regulator, valve, nipple, connector</p> <p><b>BF2</b> – Back-flushing option, hand operated, PTFE seals</p> <p><b>D</b> – Drum pump  <b>HJ</b> – Heating Jacket  <b>HP</b> – High Pressure  <b>X</b> – ATEX  <b>T</b> – Trolley  <b>P</b> – Powder pump  <b>MV</b> – Pump with solenoid valve  <b>RA</b> – Additional polishing to <math>R_a=0.5 - 0.7 \mu\text{m}</math>  <b>CLEAN</b> – The clean package to meet enlarged purity requirements for special pump applications</p>
<p><b>DM</b> - Dellmeco Pump</p> <p><b>25</b> - Port dimension, DN</p> <p><b>75</b> - Max capacity l/min at 8 bar</p>	
<p><b>H</b> - Housing material: AISI 316L</p>	
<p><b>T</b> - Diaphragm material:</p> <p><b>E</b> - EPDM</p> <p><b>N</b> - NBR</p> <p><b>T</b> - TFM/PTFE</p>	
<p><b>S</b> - Material of ball valve:</p> <p><b>E</b> - EPDM</p> <p><b>N</b> - NBR</p> <p><b>S</b> - AISI 316</p> <p><b>T</b> - PTFE</p> <p><b>U</b> - Polyurethane</p> <p><b>C</b> - Ceramic</p>	
<p><b>TC</b> – Connection:</p> <p><b>DIN</b> – DIN 11851 connection (standard)</p> <p><b>TC</b> – Tri-Clamp connection</p> <p><b>SMS</b> – SMS connection</p> <p><b>RJT</b> – Ring Joint Type connection</p>	

## 14.5. Performance curves

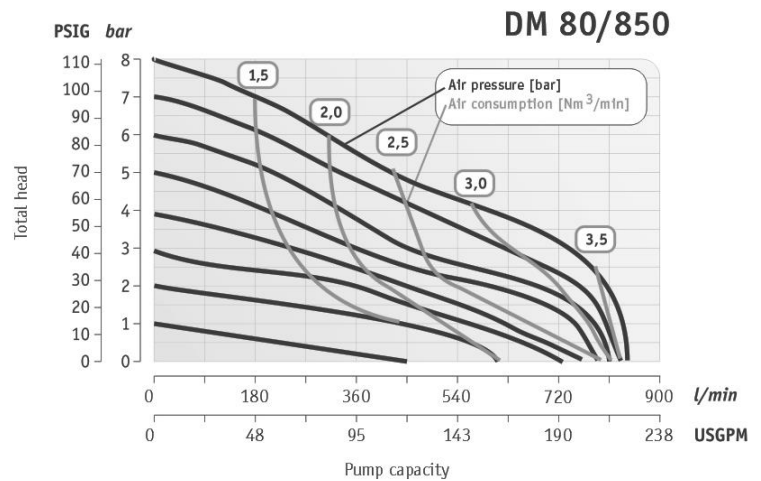
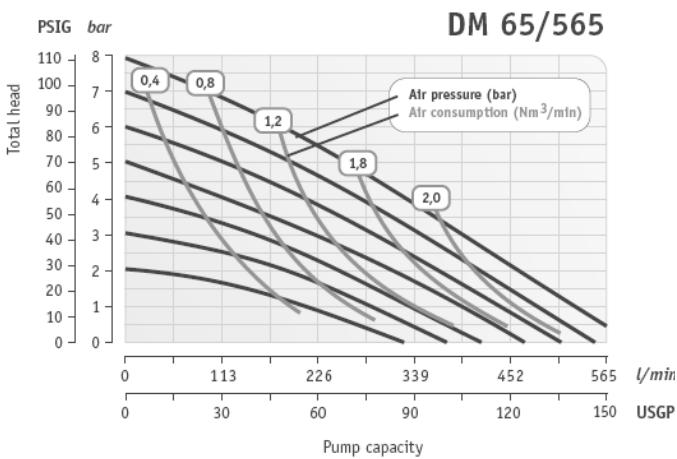
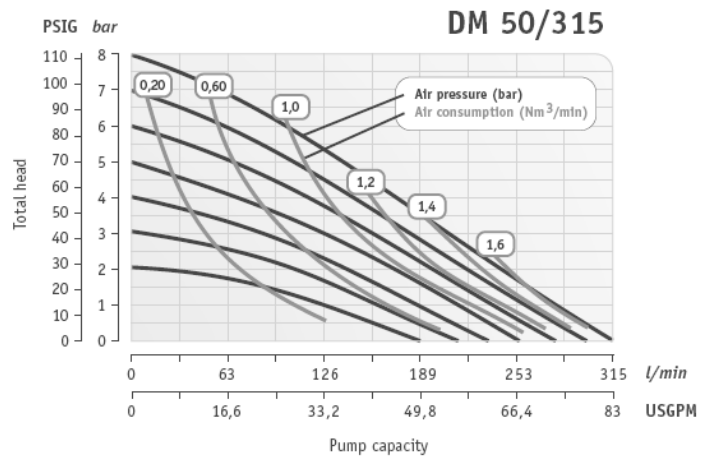
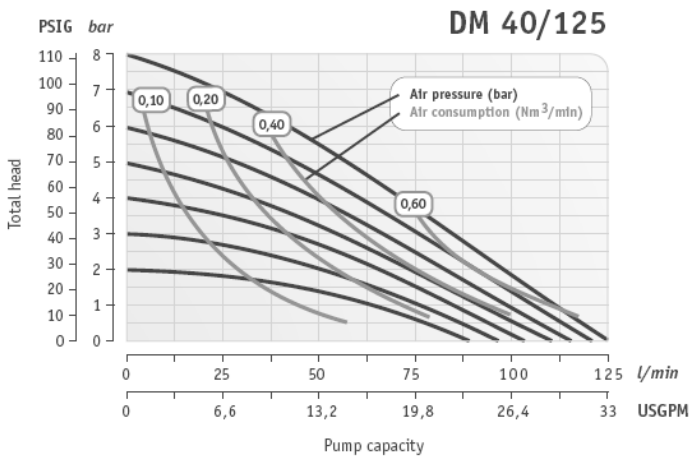
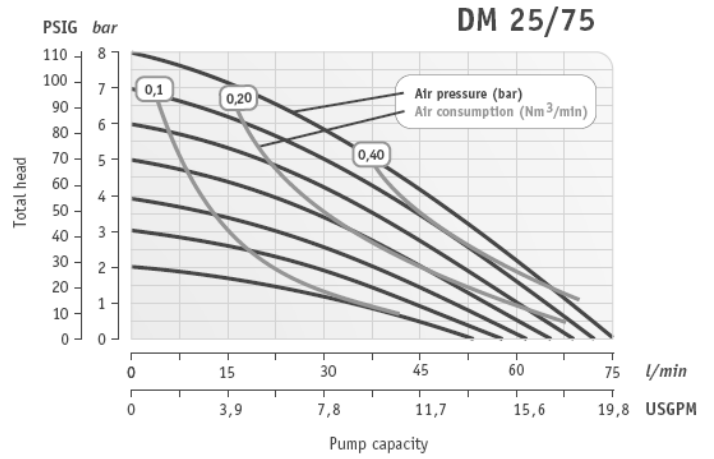
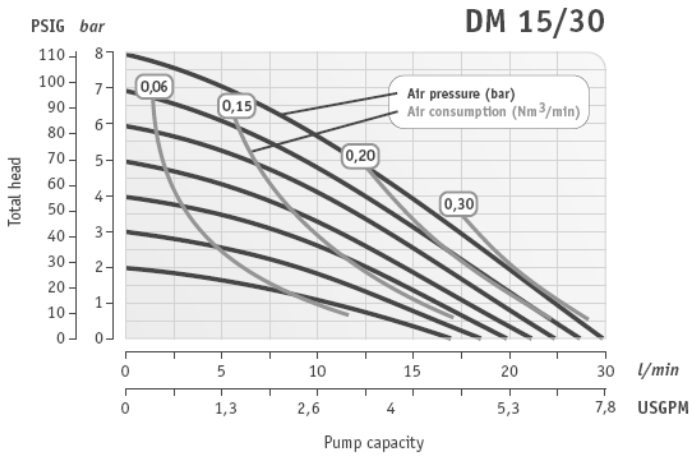

# 15. Dellmeco Active Pulsation Dampers for Hygienic Pumps

## 15.1. Main specification

DELLMECO active pulsation dampers represent the latest generation of active pulsation dampers. They are specially designed to be used along with DELLMECO pneumatic double diaphragm pumps of the Hygienic range. A general aspect to be considered is, that a pulsation damper decreases the total capacity of the system depending on the point of operation.

Before putting a DELLMECO pulsation damper into operation, make sure, that the materials of construction are resistant to the chemical to be pumped. To check this, the exact damper code is required. This code, as well as the serial number are noted on the identification plates on the damper itself.

Example of the damper type code:

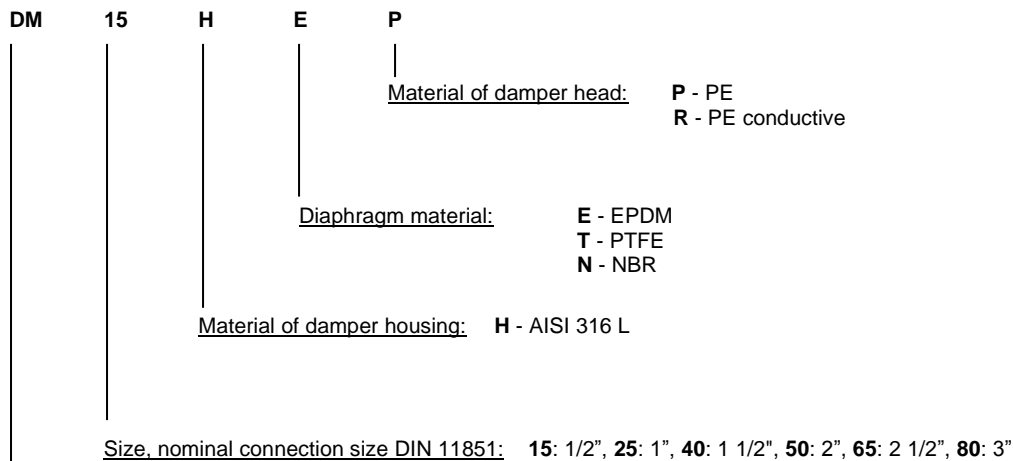

DELLMECO pulsation damper.

Air supply connection: **DM 15, DM 25:** R 1/8", **DM 40, DM 50, DM 65:** R 1/4", **DM 80:** R 1/2"

Max. operating pressure: 8 bar

Max. operating temperature: 120 °C

For inflammable liquids as well as for applications in explosion protected areas, only dampers made of PE conductive (code R) may be used. It is necessary to ground the damper separately, as the damper is not connected to the pump, which is conductive and has to be grounded itself.

The use of a pulsation damper of the series DM reduces the capacity of the complete system in dependence of the point of operation.

Before connecting the pump, take the yellow blind plugs out of air inlet which is located on the top of the damper head [41]. For correct operation, the damper absolutely needs an air-supply of its own, which has to be taken from the air-supply of the pump. Pump and pulsation damper have to be connected to the same air pressure. No stop or regulating valve may be placed between pump and damper. The driving air has to be oil-free, dry and clean. Together with the pump an empty damper has to be driven slowly. The dampers are self-regulating for all changing operating conditions.

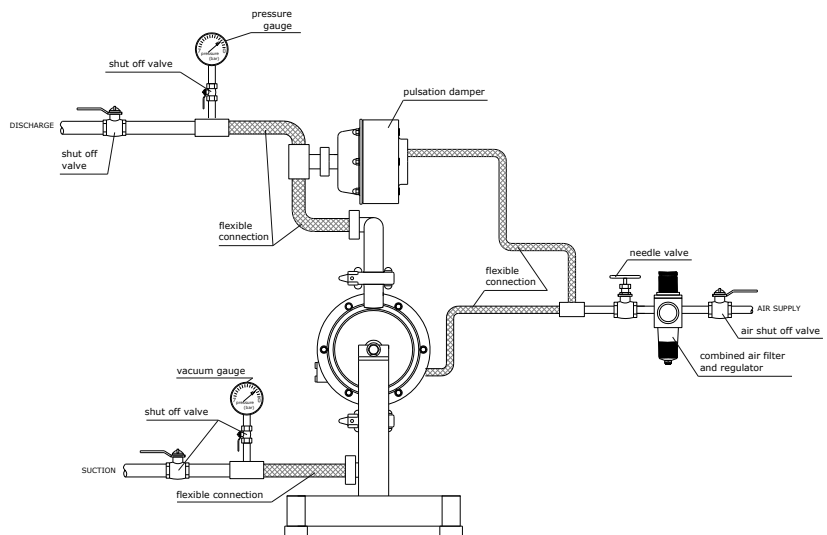



## CAUTION

- ! Before putting the pulsation damper into operation as well as after some hours of operating, the housing bolts [42] have to be tightened carefully, as the elements of construction tend to "settle". Fixing the bolts is necessary as well after longer periods of stoppage, at extreme temperature variations, transport and after dismantling.
- ! Pressure tests of the plant the pump and the damper are included in may only be carried out with the aggregate (pump and damper) disconnected from the pressure on both ports or by using the pressure the aggregate develops while operating. The load of a pressure in the plant may damage the pump and the pulsation damper.
- ! Before starting to disassemble the pump, take care that pump and damper have been emptied and rinsed. Further, both have to be cut off from any energy on the air and product side. If pump and damper is being deported from the plant, a reference about the delivered liquid has to be attached.
- ! Please respect the relevant additional security advices, if the pump and the damper have been used for aggressive, dangerous or toxic liquids.
- ! Before putting the pump and the damper back into operation, the tightness of both has to be checked.

### Disassembly instructions

Unscrew housing bolts [42] carefully. After that, all parts can be removed. Screw the diaphragm [40] off the actuator shaft [39]. A re-assembly of used piston rings [37] is impossible; they have to be replaced including the O-rings underneath. To assemble new piston rings [37] carefully shape them like kidneys with locking ring pliers and insert the rings into the grooves; completely press the rings into the grooves smoothly using some round tool.

### Spare part list, pulsation damper series

			Damper size:	DM 15	DM 25	DM 40	DM 50	DM 65	DM 80
Pos.	Quantity	Description	Material	Part no.	Part no.	Part no.	Part no.	Part no.	Part no.
36	1	Damper housing	AISI 316L	8 15 01 53	8 25 01 53	8 25 01 53	8 50 01 53	8 65 01 53	8 80 01 53
37	3	Piston ring	PPS/PTFE, PE*	1 08 90 18	1 15 85 22*	1 15 85 22*	1 25 85 22*	1 40 85 22*	1 50 85 22*
38	3	O-ring	NBR	1 08 82 10	1 15 85 10	1 15 85 10	1 25 85 10	1 40 85 10	1 50 85 10
39	1	Actuator shaft	PET / AISI 304*	8 10 40 30	8 25 40 30	8 25 40 30	8 40 40 50*	8 50 40 50*	8 80 40 50*
40	1	Diaphragm	EPDM	-	1 15 50 08	1 15 50 08	1 25 50 08	1 40 50 08	1 50 50 08
			TFM / PTFE	1 10 50 05	1 15 50 05	1 15 50 05	1 25 50 05	1 40 50 05	1 50 50 05
			NBR	-	1 15 50 10	1 15 50 10	1 25 50 10	1 40 50 10	1 50 50 10
41	1	Damper head	PE	8 10 203 20	8 25 203 20	8 25 203 20	8 40 203 20	8 50 203 20	8 80 203 20
			PE conductive	8 10 203 21	8 25 203 21	8 25 203 21	8 40 203 21	8 50 203 21	8 80 203 21
42	4 / 6* / 8**	Housing bolt	AISI 304	8 10 742 50	8 25 742 50*	8 25 742 50*	8 40 742 50*	8 50 742 50**	8 80 742 50**
43	4 / 6* / 8**	Nut covered with washer	AISI 304	1 15 145 50	1 25 145 50*	1 25 145 50*	1 40 145 50*	1 50 145 50**	1 80 145 50**
44	4 / 6* / 8**	Nut with washer	AISI 304	1 15 245 50	1 25 245 50*	1 25 245 50*	1 40 245 50*	1 50 245 50**	1 80 245 50**
45	4 / 6* / 8**	Damper head plug	PE	8 10 058 20	8 25 058 20*	8 25 058 20*	8 50 058 20*	8 65 058 20**	8 80 058 20**
46	1	Muffler	PE	8 10 99 20	8 25 99 20	8 25 99 20	8 40 99 20	8 50 99 20	8 80 99 20

# PULSATION DAMPER – exploded view

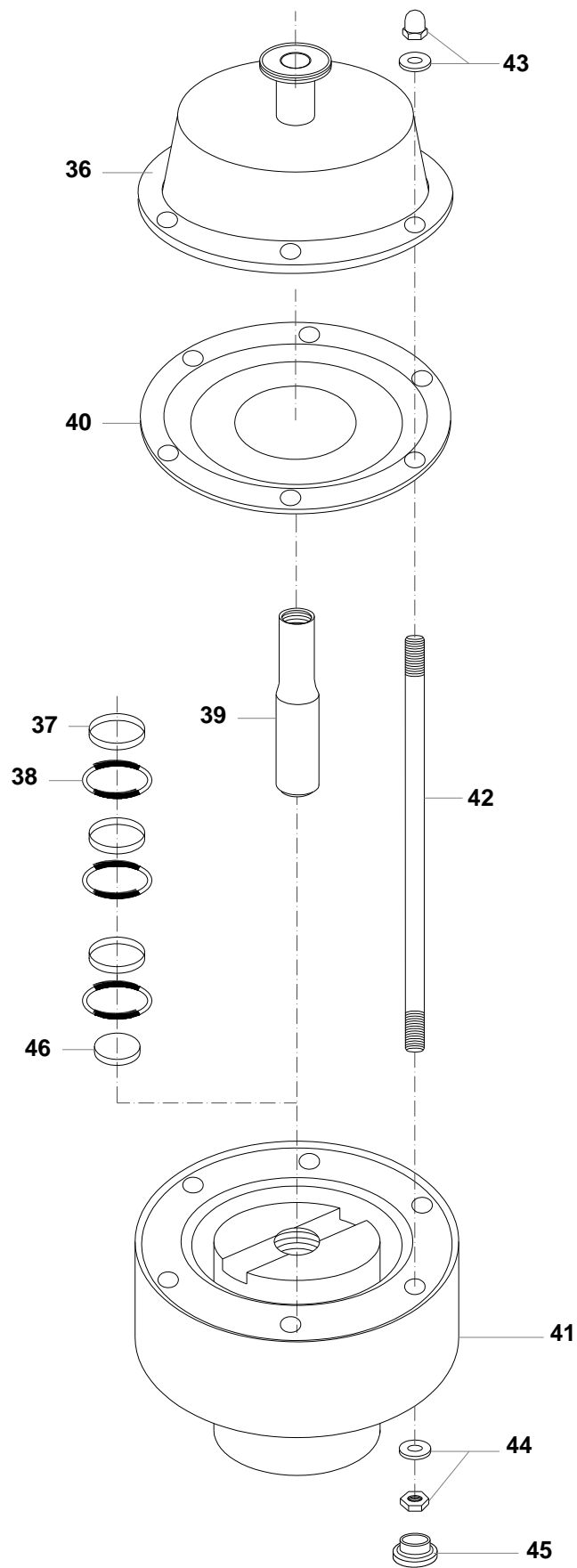

## 15.2. Appearance and dimensions of Pulsation Dampers

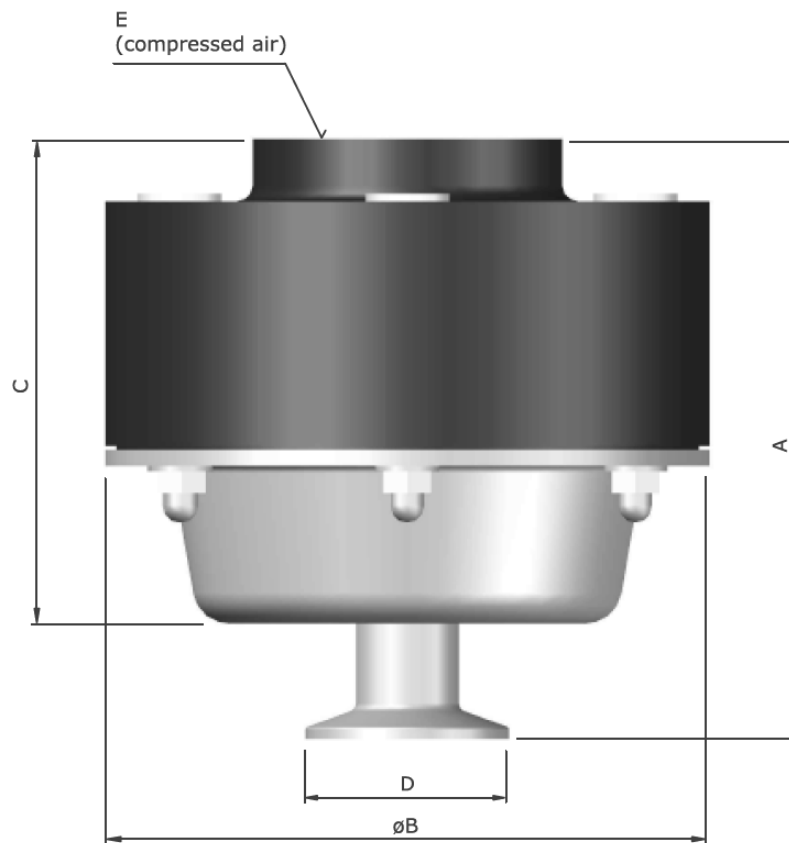

	A	$\varnothing B$	C	D			E
				TC	DN	SMS	
<b>DM 15</b>	108	110	77	1/2"	15	-	R 1/8"
<b>DM 25</b>	149	156	124	1"	25	25,00 mm	R 1/8"
<b>DM 40</b>	149	156	124	1 1/2 "	40	38,00 mm	R 1/8"
<b>DM 50</b>	178	204	150	2"	50	51,00 mm	R 1/4"
<b>DM 65</b>	220	273	198	2 1/2"	65	63,50 mm	R 1/4"
<b>DM 80</b>	265	365	240	3"	80	106,00 mm	R 1/2"

## 16. Optional Equipment

**Additional information to the operating and installation instructions  
ought to be studied before installing the pump**

For special requirements DELLMECO pneumatic diaphragm pumps of the Hygienic Series can be furnished with several optional equipment. The pump code informs, which of these are included in the pump.

### 16.1. Barrier Chamber System (option code BC1, BC2, BC3)

To comply with high safety standards, the barrier system replaces the standard diaphragm [4] by a tandem arrangement of two diaphragms [4, 59] and barrier chambers [52, 53] of conductive PE filled with a non-conductive liquid (de-ionized water) in between. To ensure the correct operation of the pump, the barrier chambers [52, 53] have to be filled completely. Therefore, they are monitored by liquid sensors [60]. After loosening the plug [57] the barrier liquid can be refilled. In case a diaphragm breaks, the conductivity of the barrier liquid rises which is registered by the conductivity sensors [56]. The minimum conductivity of 22  $\mu$ S covers a wide range of media. Otherwise, a conductive barrier liquid can be filled into the chamber, so that the liquid emerging in case of a diaphragm rupture causes a decrease in conductivity to be registered. After using for some time the de-ionized water can be polluted with germs. In this case the water needs to be replaced.

The barrier system is available in three variations:

- BC 1 Barrier system with sensors, standard
- BC 2 Barrier system complete with sensors and controllers
- BC 3 Barrier system complete with sensors and controllers for explosion-proof zone

The four conductivity sensors [56] are pre-installed. After connection of the wire (wire not part of supply) only the PG-threads have to be screwed onto. Both liquid sensors [60] are installed completely.

The sensors can either be connected to an existing controller (code BC1) or to the controller included (codes: BC2 and BC3). The wiring diagram and technical data can be found on the controller itself. For further details, please refer to the data delivered by the manufacturers of the components. The controllers have to be installed in a suitable cabinet.

Spare part list, barrier chamber system

					Pump size	DM 15	DM 25	DM 40	DM 50	DM 65
Code	Position	Quantity	Description	Material	Part no.	Part no.	Part no.	Part no.	Part no.	
BC 1	25	1	Pump support	AISI 304	4 15 096 50	4 25 096 50	4 40 096 50	4 50 096 50	4 65 096 50	
	47	1	Manifold inlet DIN	AISI 316L	4 15 030 53	4 25 030 53	4 40 030 53	4 50 030 53	4 65 030 53	
			Manifold inlet SMS		-	4 25 031 53	4 40 031 53	4 50 031 53	4 65 031 53	
			Manifold inlet TC		4 15 032 53	4 25 032 53	4 40 032 53	4 50 032 53	4 65 032 53	
		1	Manifold outlet DIN		4 15 130 53	4 25 130 53	4 40 130 53	4 50 130 53	4 65 130 53	
			Manifold outlet SMS		-	4 25 131 53	4 40 131 53	4 50 131 53	4 65 131 53	
			Manifold outlet TC		4 15 132 53	4 25 132 53	4 40 132 53	4 50 132 53	4 65 132 53	
	48	4 / 6* / 8**	Barrier chamber housing bolt	AISI 304	4 15 042 50	4 25 042 50*	4 40 042 50*	4 50 042 50**	4 65 042 50**	
	49	1	Barrier chamber set screw shaft	AISI 304	1 10 41 50	1 15 41 50	1 25 41 50	1 40 41 50	1 50 41 50	
	50	2	Spacer	PET	1 10 63 30	1 15 63 30	1 25 63 30	-	-	
	51	2	Spacer bolt	AISI 304	1 10 43 50	-	-	-	-	
	52	1	Left barrier chamber	PE cond.	4 10 02 21	4 15 02 21	4 25 02 21	4 40 02 21	4 50 02 21	
	53	1	Right barrier chamber	PE cond.	4 10 102 21	4 15 102 21	4 25 102 21	4 40 102 21	4 50 102 21	
	54	2	Sensor sleeve	PE	4 15 62 20	4 15 62 20	4 15 62 20	4 15 62 20	4 15 62 20	
	55	2	Sensor sleeve o-ring	FPM	1 08 82 09	1 08 82 09	1 08 82 09	1 08 82 09	1 08 82 09	
	56	4	Conductivity sensor	diverse	9 15 15 00	9 15 15 00	9 15 15 00	9 15 15 00	9 15 15 00	
	57	2	Plug	PA	1 15 48 40	1 15 48 40	1 15 48 40	1 15 48 40	1 15 48 40	
	58	2	Plug o-ring	FPM	1 15 74 09	1 15 74 09	1 15 74 09	1 15 74 09	1 15 74 09	
59	2	Inner diaphragm	EPDM	1 10 51 08	1 10 51 08	1 15 51 08	1 25 51 08	1 40 51 08		
60	2	NAMUR liquid sensor	diverse	9 15 12 00	9 15 12 00	9 15 12 00	9 15 12 00	9 15 12 00		
61	2	Liquid sensor o-ring	FPM	1 15 75 09	1 15 75 09	1 15 75 09	1 15 75 09	1 15 75 09		
BC 2			as BC1, but additionally contains:							
	-	1	Controller	diverse	9 15 14 00	9 15 14 00	9 15 14 00	9 15 14 00	9 15 14 00	
	-	1	Conductivity measuring trans.	diverse	9 15 13 00	9 15 13 00	9 15 13 00	9 15 13 00	9 15 13 00	
BC 3			as BC2, but for EExia II C:							
	-	1	Controller	diverse	9 15 14 00	9 15 14 00	9 15 14 00	9 15 14 00	9 15 14 00	
	-	1	Conductivity measuring trans.	diverse	9 15 08 00	9 15 08 00	9 15 08 00	9 15 08 00	9 15 08 00	



Exploded view, barrier chamber system for DM 15

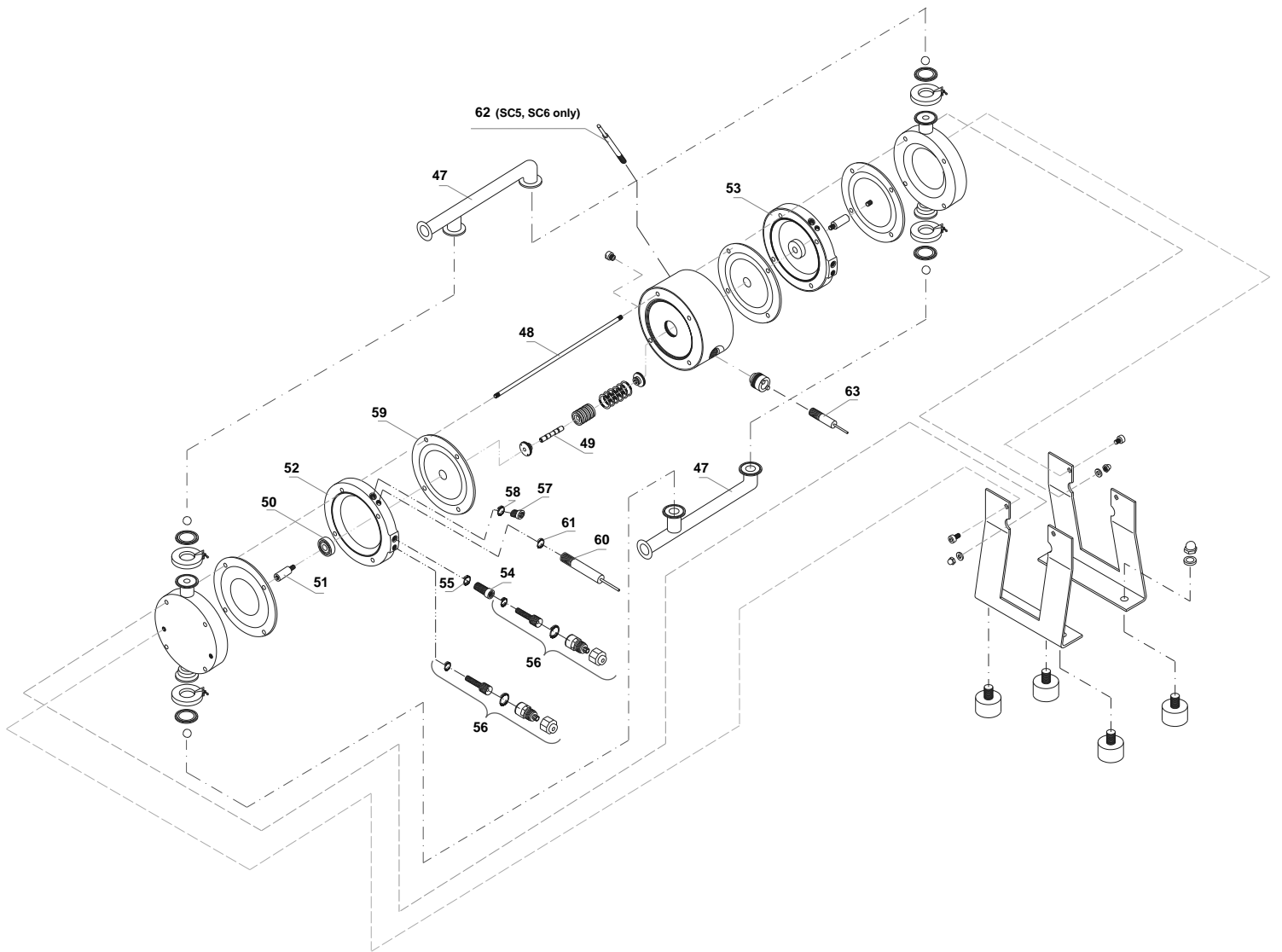

Exploded view, barrier chamber system for DM 25, 40, 50, 65

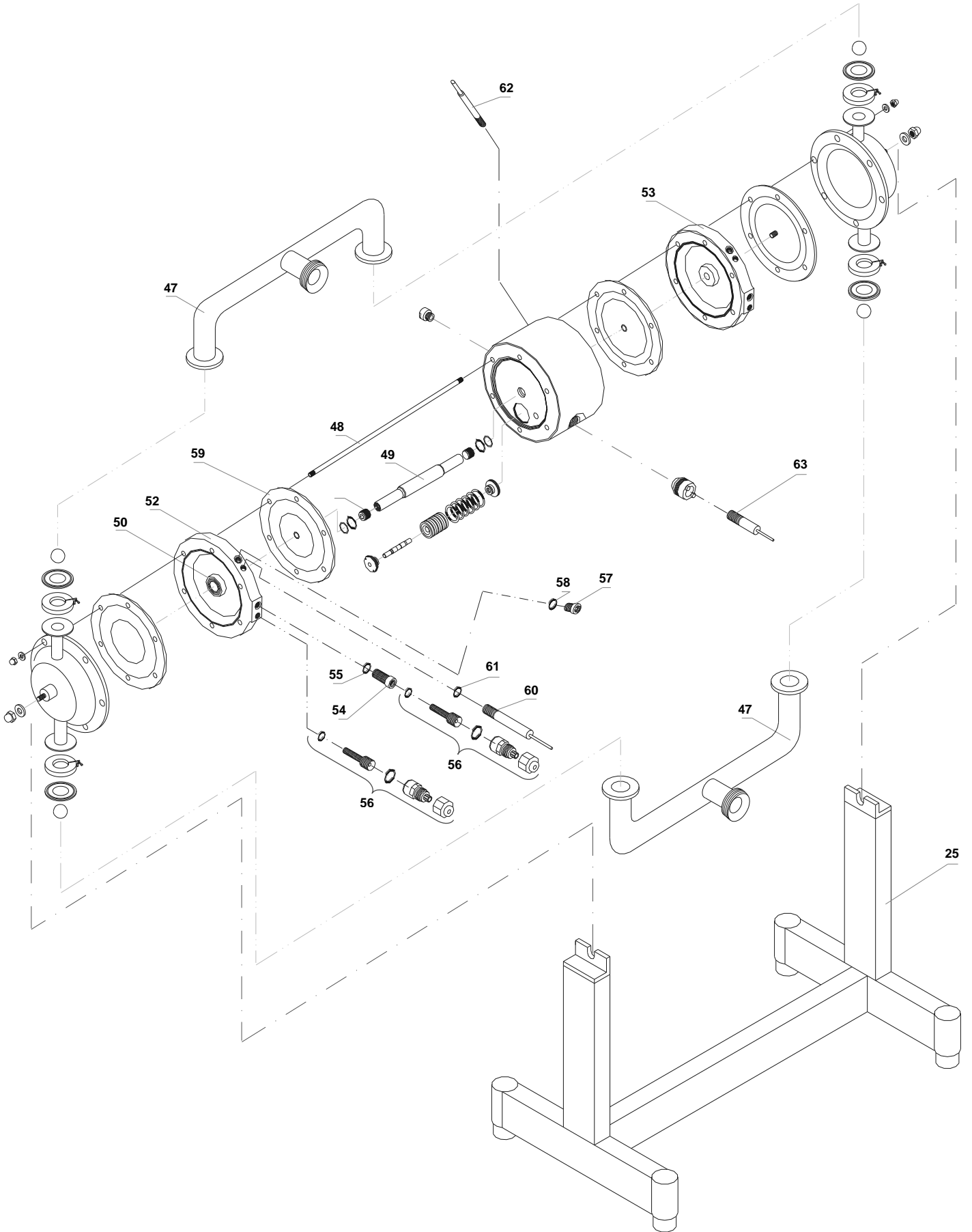

## Appearance and dimensions (pump with Barrier Chamber System)

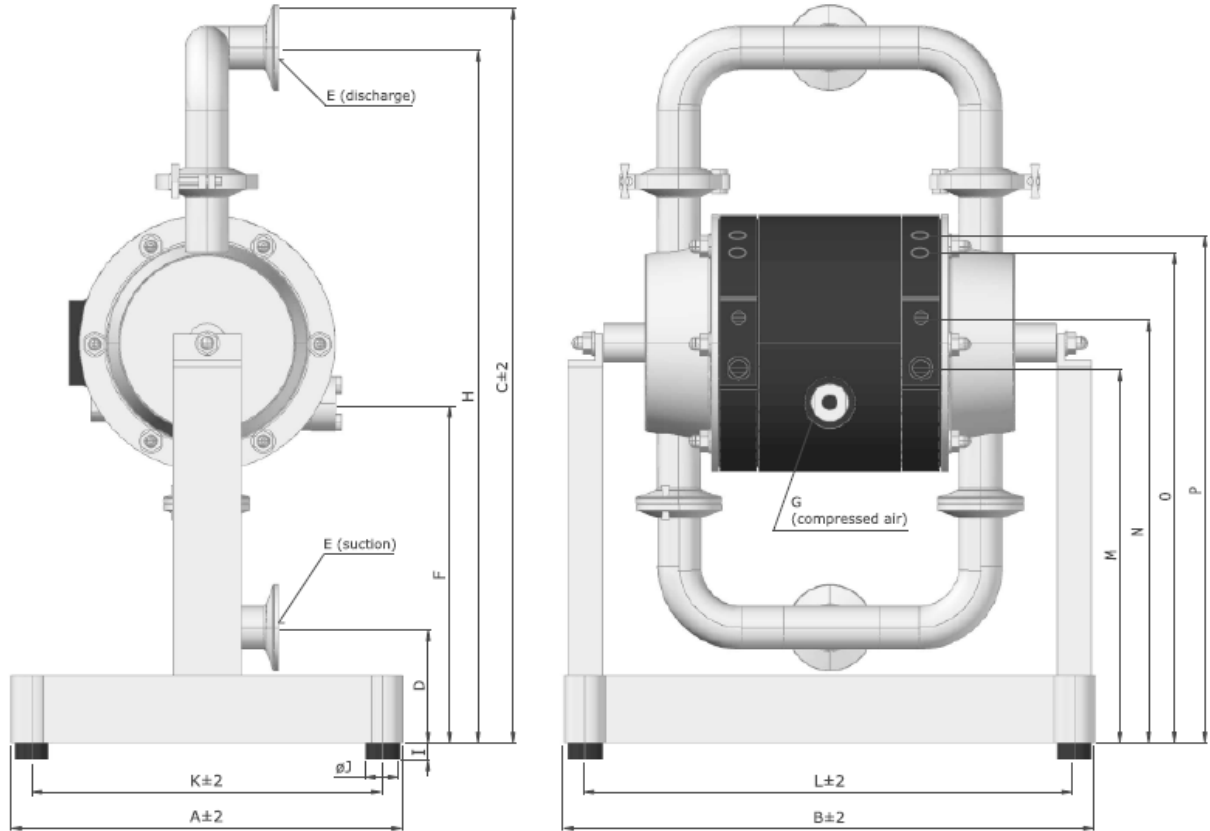

	A	B	C	D	E			F	G	H	I	ØJ	K	L	M	N	O	P
					TC	DN	SMS											
<b>DM 15 / 30</b>	150	210	299	46	1/2"	15	-	162	R 1/8"	282	18	30	116	148	139	162	206	224
<b>DM 25 / 75</b>	230	310	419	75	1"	25	25	204	R 1/4"	394	18	30	206	284	197	222	303	321
<b>DM 40 / 125</b>	256	337	465	67	1 1/2"	40	38	221	R 1/4"	440	18	30	226	307	245	275	350	370
<b>DM 50 / 315</b>	350	435	679	102	2"	50	51	247	R 1/4"	640	18	30	325	405	342	367	474	485
<b>DM 65 / 565</b>	350	507	888	126	2 1/2"	65	63.5	357	R 1/4"	842	18	30	326	483	452	477	620	632

## 16.2. Stroke Counting (option code SC1, SC2, SC3, SC5, SC6)

### a) Option code SC1, SC2, SC3

A sensor is installed in the central pump housing to count the strokes. The diaphragm movement is scanned without contact by this sensor: a safe form of monitoring totally independent of external influences and the pump's mode of operation. The issued sensor pulses can be output to existing detectors or to a stroke counter, which can also be supplied on request. When the preset value is reached, the stroke counter outputs a signal which can then be processed further, for instance in order to shut down the pump via a solenoid valve.

**The stroke counting system is available in three variations:**

- SC 1 Stroke sensor (Namur), also for explosion-proof zone
- SC 2 Stroke counting system complete with sensor and stroke counter
- SC 3 Stroke counting system complete with sensor, stroke counter and controller for explosion-proof zone

In case only the sensor is included (code SC1), it has to be connected to an existing controller with Namur inlet. For applications an explosion-proof device is required for (code SC3) the intrinsically safe controller has to be installed between the sensor and the counter. The wiring diagram and technical data can be found on the electric units themselves. For further details, please refer to the data delivered by the manufacturers of the components. The controllers have to be installed in a suitable cabinet.

## b) Option code SC5, SC6

Differently from the optional equipment codes SC1-SC3, the strokes of the pump are registered pneumatically on the codes SC5 and SC6. The pressure transmitter registers the changes in pressure within the air chamber behind one of the diaphragms and it converts the pneumatic impulse into an electrical signal.

**The pneumatic stroke counting system is available in two types:**

- **SC 5** consist of:
  - pressure transmitter 1-10 bar
  - socket with cable 2,5 m
  - adaptor elbow NPT ¼ (or adaptor straight M5 only for DM 15/30 pump)
  - hose DN 4/6; 2,5m
- **SC 6** consist of:
  - SC 5 plus stroke counter

For assembly, screw the adaptor straight into the pressure transmitter (connection P1) and adaptor elbow into the additional air connection of the pump (it is possible that the adaptors are already installed). The position of the air inlet varies depending in the pump type and the pump size (see comments below). Link up both adaptors with the hose. Connect the socket to the electrical connection plug of the pressure transmitter and the cable to existing registering devices (Code SC5) resp. to the enclosed stroke counter (Code SC6). Technical data, connection schemes and further details can be found in the technical documentation delivered by the manufacturers of the pressure transmitter and the stroke counter.



**CAUTION**



The pneumatic stroke counting system requires a minimum air pressure of 1.5 bar for optimal function.

The air inlet for the pneumatic stroke counting system must not be confused with the actual air inlet of the pump. Therefore, you will find some advises adapted to the pump type and the pump size.

### Spare part list, stroke counting

Code	Pos.	Quantity	Description	Material	Pump size:					
					DM 15	DM 25	DM 40	DM 50	DM 65	DM 80
					Part no.	Part no.	Part no.	Part no.	Part no.	Part no.
SC 1	2	1	Center housing for sensor	PE	-	1 15 09 20	1 25 09 20	1 40 09 20	1 50 09 20	1 80 09 20
		1	Center housing for sensor	PE conductive	-	1 15 09 21	1 25 09 21	1 40 09 21	1 50 09 21	1 80 09 21
	62	1	Stroke sensor	diverse	-	9 15 16 00	9 15 16 00	9 15 16 00	9 15 16 00	9 15 16 00
SC 2			<b>as SC 1, but additionally contains:</b>							
	-	1	Clamp amplifier	diverse	-	9 15 18 00	9 15 18 00	9 15 18 00	9 15 18 00	9 15 18 00
	-	1	Stroke counter	diverse	-	9 15 17 00	9 15 17 00	9 15 17 00	9 15 17 00	9 15 17 00
SC 3			<b>as SC 1, but additionally contains:</b>							
	-	1	Level controller	diverse	-	9 15 14 00	9 15 14 00	9 15 14 00	9 15 14 00	9 15 14 00
	-	1	Stroke counter	diverse	-	9 15 17 00	9 15 17 00	9 15 17 00	9 15 17 00	9 15 17 00
SC 5	-	1	Center housing with additional air connection R ¼"	PE	1 10 109 20	1 15 109 20	1 25 109 20	1 40 109 20	1 50 109 20	-
	-	1		PE conductive	1 10 109 21	1 15 109 21	1 25 109 21	1 40 109 21	1 50 109 21	-
	-	1	Adaptor elbow	PP	-	1 08 092 28	1 08 092 28	1 08 092 28	1 08 092 28	-
	-	1	Adaptor straight	PP	1 08 192 28	-	-	-	-	-
	-	1	Hose 2,5 m	PE	1 08 292 28	1 08 292 28	1 08 292 28	1 08 292 28	1 08 292 28	-
	-	1	Pressure transmitter	diverse	9 08 28 00	9 08 28 00	9 08 28 00	9 08 28 00	9 08 28 00	-
	-	1	Socket with cable 2,5 m	diverse	1 08 392 00	1 08 392 00	1 08 392 00	1 08 392 00	1 08 392 00	-
SC 6			<b>as SC 5, but additionally contains:</b>							
	-	1	Stroke counter	diverse	9 15 17 00	9 15 17 00	9 15 17 00	9 15 17 00	9 15 17 00	-

### 16.3. Diaphragm Monitoring (option code DM1, DM2)

Although DELLMECO diaphragms with integrated metal core are designed for an optimum service life, the diaphragm remains a wear part. If it breaks, liquid can leak into the center housing and possibly emerge through the muffler. This can be prevented simply and effectively with the DELLMECO diaphragm monitoring.

A capacitive diaphragm sensor is mounted in the muffler [17] of the pump, which registers any liquid approaching the sensor, no matter whether the liquid is conductive or not. Hence, a fast reaction to a damage of a diaphragm becomes possible. In case of humid surrounding air a false alert may occur despite operating the pump with dried compressed air.

The diaphragm monitoring system is available in two variations:

- DM1 Diaphragm sensor (Namur), also for explosion-proof area
- DM2 Diaphragm monitoring system complete with sensor and controller

The diaphragm sensor can either be connected to an existing controller with Namur inlet (code DM1) or to the controller included (code DM2). The wiring diagram and technical data can be found on the controller itself. For further details, please refer to the data delivered by the manufacturers of the components. The controllers have to be installed in a suitable cabinet.

#### Spare part list, diaphragm monitoring

					Pump size:				
					DM 15	DM 25	DM 40	DM 50	DM 65
Code	Position	Quantity	Description	Material	Part no.	Part no.	Part no.	Part no.	Part no.
DM 1	63	1	Diaphragm sensor, Namur	diverse	9 15 19 00	9 15 19 00	9 15 19 00	9 15 19 00	9 15 19 00
DM 2	63	1	Diaphragm sensor, Namur	diverse	9 15 19 00	9 15 19 00	9 15 19 00	9 15 19 00	9 15 19 00
	-	1	Controller	diverse	9 15 14 00	9 15 14 00	9 15 14 00	9 15 14 00	9 15 14 00

### 16.4. Back Flushing System (option code BF1, BF3)

A pump equipped with the back flushing system can be emptied along with an inclining discharge line while being installed within the plant. It consist of a ball-lift system in the side housings which can be activated by manual valves.

Open the manual valves by turning blocking pins [67] clockwise (right turn), approx. 90°. The pump should be kept in operation meanwhile. Slow down the pump slowly and finally stop it. The pump is drained entirely on both sides (suction and discharge).

The side housing o-rings are made from EPDM (BF1 option), or FPM (BF3 option).

**ATTENTION:** Blocking pins may be rotated only in clockwise direction to avoid unscrewing of cap [70] - see the drawing on page 38 (arrows show direction of rotating of blocking pins). To close manual valves, you should turn clockwise blocking pins [67] around – to the original position, before activating BF system.

## Appearance of Back Flushing System for DM 80/850 H..

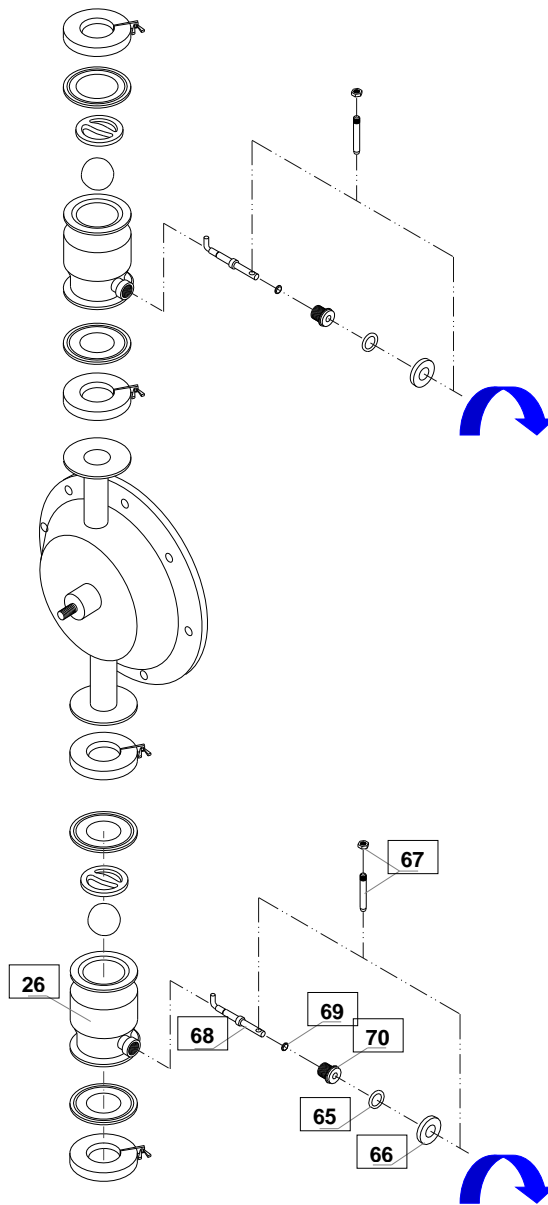

### Spare part list, Back Flushing system (Option BF)

DM 80/850					
Code	Item	Pc.	Description	Material	Part no.
BF1, BF3	26	4	Valve seat for BF option	AISI 316L	4 80 239 53
	65	4	O-ring	EPDM	4 80 372 08
				FPM	4 80 372 09
	66	4	Washer	AISI 316L	4 80 157 53
	67	4	Blocking pin	AISI 316L	3 80 342 53
	68	4	Lever	AISI 316L	4 80 457 53
	69	4	Packing washer	PTFE	4 80 357 23
70	4	Screw cap	AISI 316L	4 80 957 53	

## 16.5. High Pressure (option code HP)

DELLMECO Hygienic diaphragm pumps can be fitted with High Pressure option (except DM 15/30 H.. pump).

### Pressure adjustment

The required pressure in the system is comfortably adjusted by the height of the air pressure supplying the pump. For a required pressure of 12 bar the HP pump has to be supplied with 6 bar when the pump with a pressure transmission of 1:2 is applied. In the case that higher pressures are necessary or there is only a lower air pressure available, the HP pump with 1:4 transmission is applied.

### Appearance and dimensions of High Pressure pump

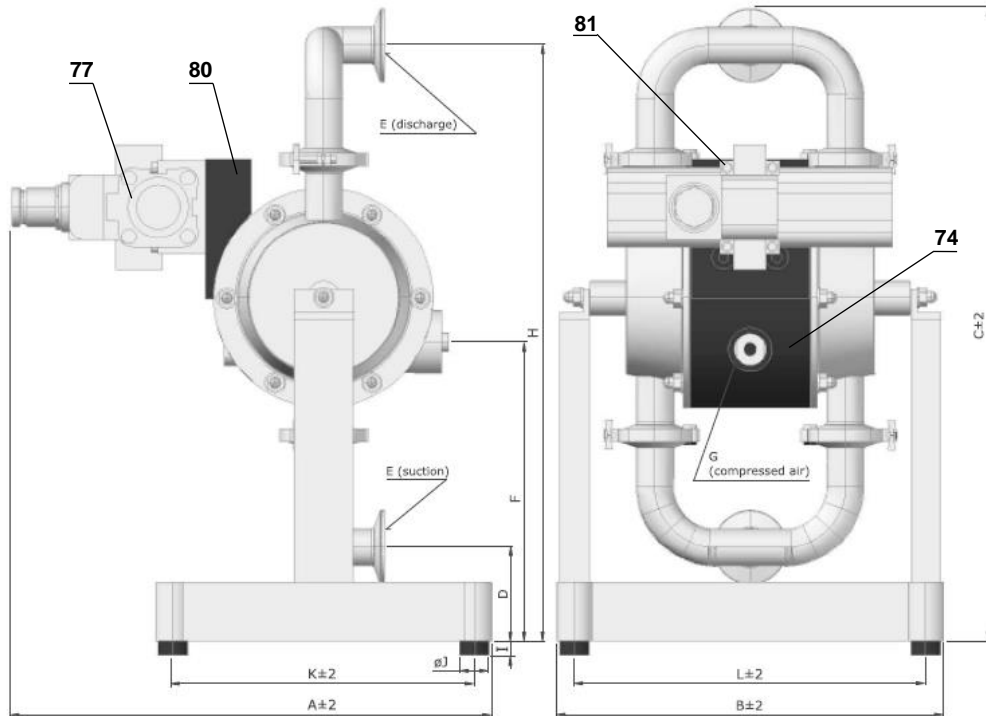

	A	B	C	D	E			F	G	H	I	ØJ	K	L
					TC	DN	SMS							
DM 25/75	377	165	419	46	1"	25	25	204	R 1/4"	394	18	30	206	238
DM 40/125	403	287	465	67	1 1/2"	40	38	221	R 1/4"	440	18	30	226	257
DM 50/315	452	387	679	102	2"	50	51	247	R 1/2"	640	18	30	325	357
DM 65/565	573	459	888	126	2 1/2"	65	63,5	357	R 1/2"	842	18	30	326	435

### Spare part list, high pressure system

Pump size:					DM 25/75	DM 40/125	DM 50/315	DM 65/565
Code	Item	Pc.	Description	Material	Part no.	Part no.	Part no.	Part no.
HP	74	1	Center housing for HP option	PE	1 15 210 20	1 25 210 20	1 40 210 20	1 50 210 20
				PE conductive	1 15 210 21	1 25 210 21	1 40 210 21	1 50 210 21
	77	1	Air pressure booster	diverse	9 15 64 00	9 15 64 00	9 40 64 00	9 50 64 00
	80	1	Booster connection	PE conductive	3 20 364 21	3 25 364 21	3 40 364 21	3 50 364 21
	81	4	Connection bolt	AISI 304	3 20 242 50	3 20 242 50	3 20 242 50	3 20 242 50

**Performance curves**

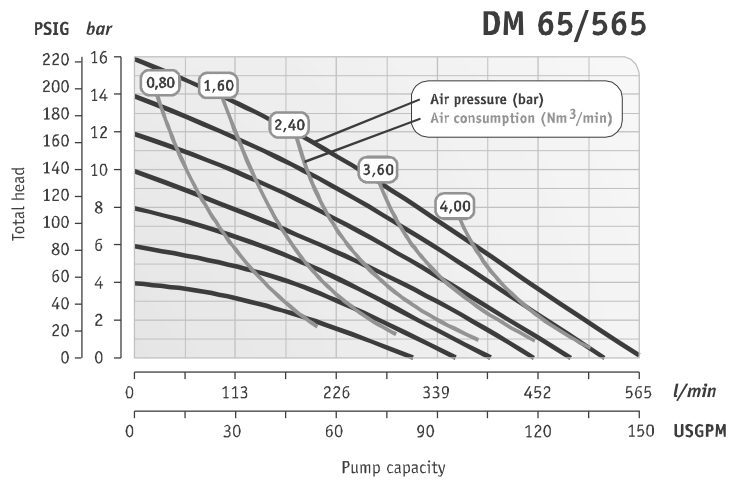
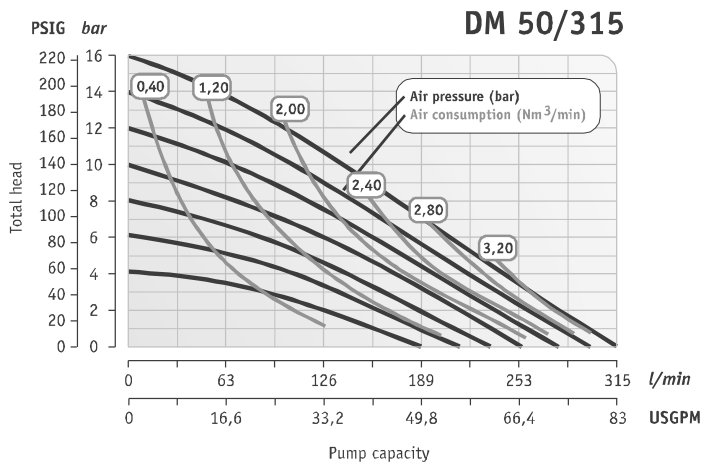
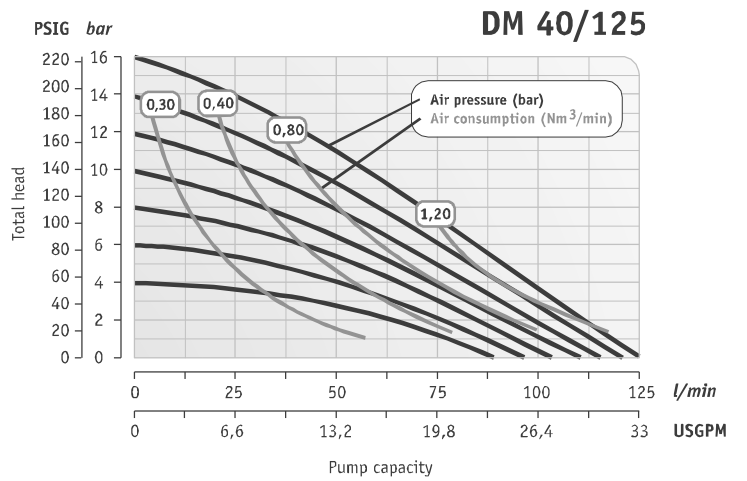
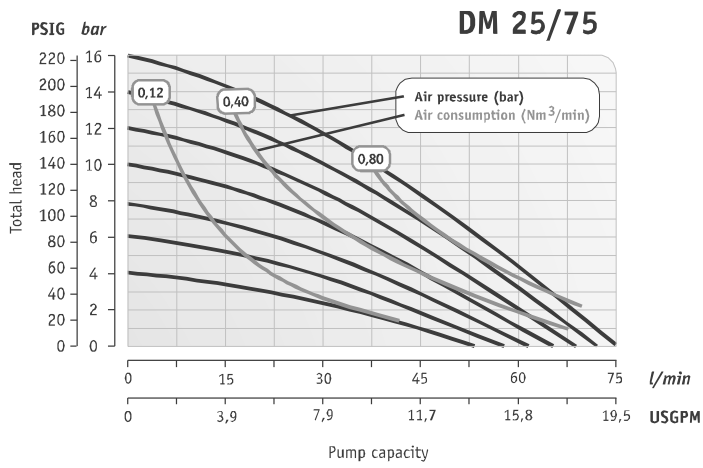



## 16.6. Heating Jacket (option code HJ)

The heating jacket is used when the pumped product has to maintain a specific temperature, high or low, throughout the process. A heating or cooling medium (hot water, steam, oil) is continuously circulated in the heating jacket. The jacket is covering all the wetted parts of the pump. Available on hygienic (AISI 316L polished) series pumps from DM 25/75 H-Series model.

Technical data for Heating Jacket (option code HJ):

- Maximum temperature: 120°C
- Maximum pressure: 3 bar
- Flow rate: depending on product temperature
- Medium: hot water, steam, oil
- Connections: 3/8"

### Appearance of hygienic pump with Heating Jacket option

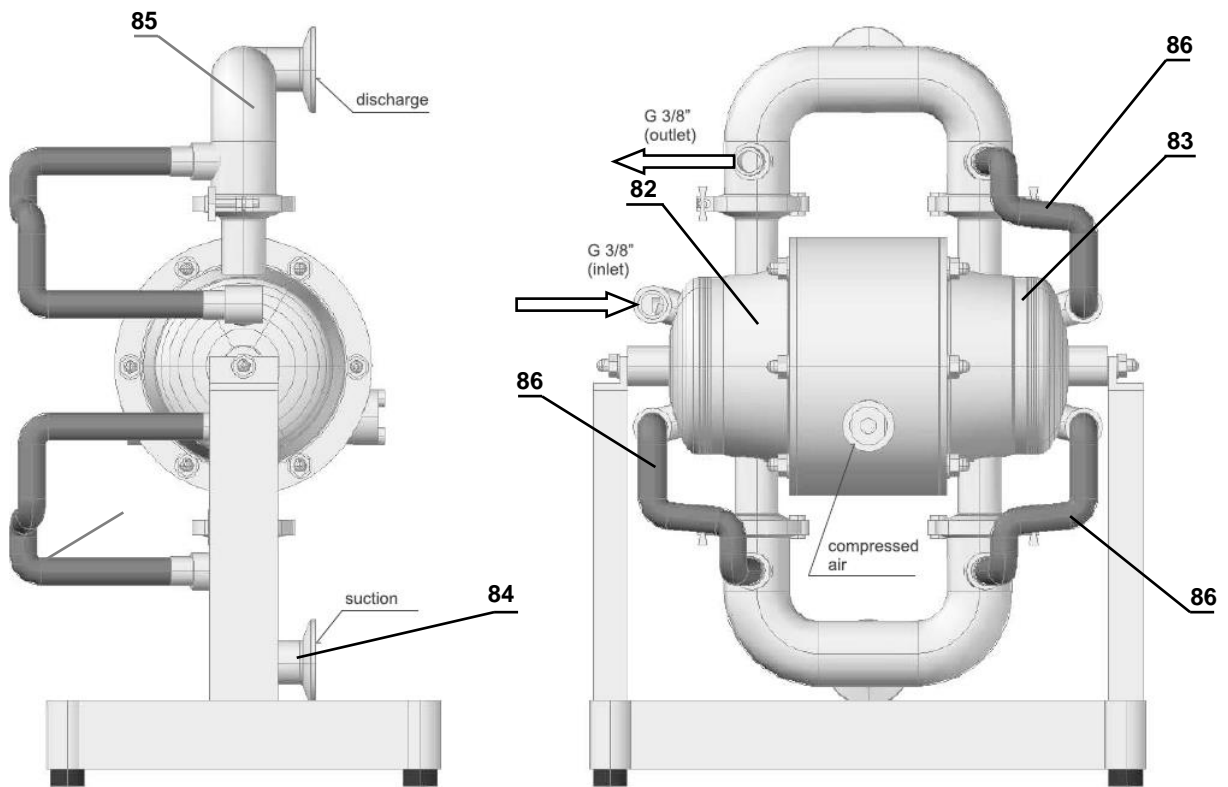

### Spare part list, high pressure system

Pump size:					DM 25/75	DM 40/125	DM 50/315	DM 65/565
Code	Item	Pcs.	Description	Material	Part no.	Part no.	Part no.	Part no.
HJ	82	1	Left side housing for HJ Option	AISI 316L	4 25 801 53	4 40 801 53	4 50 801 53	4 65 801 53
	83	1	Right side housing for HJ Option	AISI 316L	4 25 901 53	4 40 901 53	4 50 901 53	4 65 901 53
	84	1	Inlet DIN for HJ Option	AISI 316L.	4 25 130 53	4 40 130 53	4 50 130 53	4 65 130 53
		1	Inlet SMS for HJ Option	AISI 316L	4 25 131 53	4 40 131 53	4 50 131 53	4 65 131 53
		1	Inlet TC for HJ Option	AISI 316L	4 25 132 53	4 40 132 53	4 50 132 53	4 65 132 53
	85	1	Outlet DIN for HJ Option	AISI 316L	4 25 133 53	4 40 133 53	4 50 133 53	4 65 133 53
		1	Outlet SMS for HJ Option	AISI 316L	4 25 134 53	4 40 134 53	4 50 134 53	4 65 134 53
		1	Outlet TC for HJ Option	AISI 316L	4 25 135 53	4 40 135 53	4 50 135 53	4 65 135 53
	86	3	Hose connection	diverse	4 25 92 00	4 40 92 00	4 50 92 00	4 65 92 00
	87		Pump stand for HJ Option	AISI 304	4 25 196 50	4 40 196 50	4 50 196 50	4 65 196 50

## 16.7. Flap Valve (option code FVF) for Hygienic Series Pumps

Flap Valve Option in Hygienic Series Pumps allows for pumping liquids with size of particles bigger than in the case of standard ball valve equipped Hygienic Series Pump. It also protects these particles from destroying during pumping process (there are no ball stoppers welded inside which reduce maximum particle size).

Flap Valve system provides easy maintenance and cleaning coupled with smooth and trouble-free operation. It is available for pump size from DM 40/125 ... (1 1/2") up to DM 80/850 (3"). Maximum size of particles is:

- For DM 40/125 H.-FVF, maximum size is 22 mm;
- For DM 50/315 H.-FVF, maximum size is 38 mm;
- For DM 65/565 H.-FVF, maximum size is 48 mm;
- For DM 80/855 H.-FVF, maximum size is 66 mm.

Examples of applications are food (chopped tomatoes) and poultry (chicken necks, hearts, livers, feet) products with big and delicate solids.

Hygienic Pumps with Flap Valve Option also ensures better dry suction.

Flap Valve Hygienic Pump differs from standard Hygienic Pump by side housing (except DM 80/850 Model), valve type, manifold outlet and pump stand. However, this option still can be implemented on already existing standard pumps.

### Spare part list, high pressure system

Pump size:					DM 40/125	DM 50/315	DM 65/565	DM 80/850
Code	Item	Pcs.	Description	Material	Part no.	Part no.	Part no.	Part no.
FVF	88	2	Side housing for Flap Valve option	AISI 316L	4 40 F1A 53	4 50 F1A 53	4 65 F1A 53	4 80 01 53
	6	4/6*/8**	Clamp	AISI 304	4 40 36 50**	4 50 36 50*	4 65 36 50	4 80 36 50*
	7	4/6*/8**	Sealing	PTFE	4 40 70 23**	4 50 70 23*	4 65 70 23	4 80 70 23*
	89	4	Flap check housing	AISI 316L	4 40 254 53	4 50 254 53	4 65 254 53	4 80 254 53
	90	4	Flapper	AISI 316L	4 40 260 53	4 50 260 53	4 65 260 53	4 80 260 53
	91	2/4*/-	Distance sleeve	AISI 316L	4 40 296 53*	4 50 296 53	-	4 80 296 53
		1	Manifold outlet DIN for FVF option	AISI 316L	4 40 533 53	4 50 533 53	4 65 533 53	4 80 533 53
	92	1	Manifold outlet SMS for FVF option	AISI 316L	4 40 534 53	4 50 534 53	4 65 534 53	4 80 534 53
		1	Manifold outlet TC for FVF option	AISI 316L	4 40 535 53	4 50 535 53	4 65 535 53	4 80 535 53
	93	1	Pump stand for FVF option	AISI 304	4 40 396 50	4 50 396 50	4 65 396 50	4 80 396 50

## Appearance of Flap Valve Option

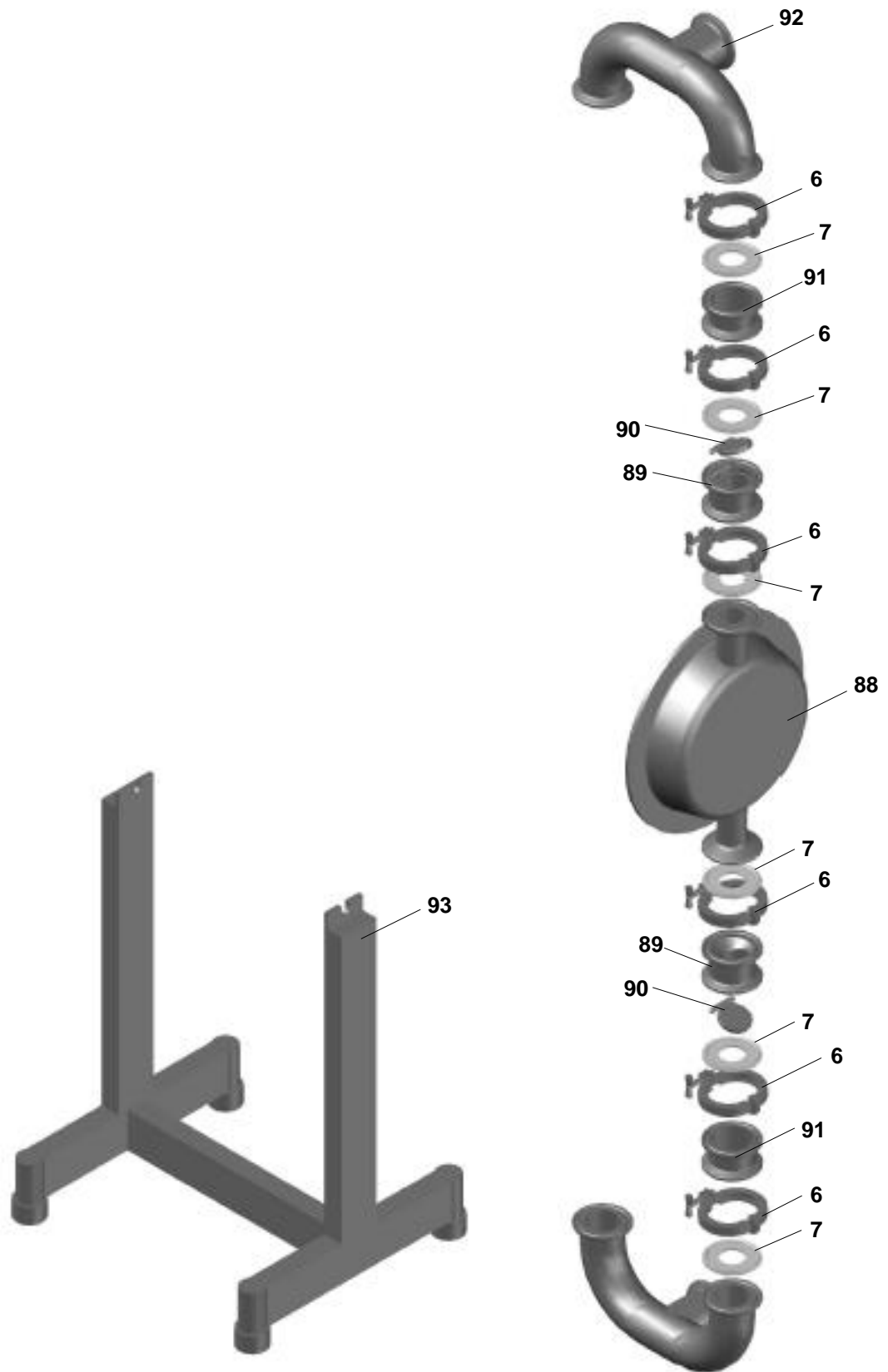

# 17. Limited warranty

This product is shipped to customers only after meeting strict inspection standards. If an abnormality occurs during normal operation in accordance with the operating instructions and other operating cautions within the warranty period (24 months after date of purchase) that can be attributed to a manufacturing defect, the defective parts of this product will be serviced or the product will be replaced free of charge. However, this warranty will NOT cover compensation for incidental damage or any malfunction listed below.

## 1. Warranty period

This warranty is valid for 24 months after the date of purchase.

## 2. Warranty

If, during the warranty period, any of the material of the genuine parts of this product or the workmanship of this product is found defective, and is so verified by our company, the servicing cost will be fully covered by our company.

## 3. Exclusion

Even during the warranty period, this warranty DOES NOT cover the following:

- 1) Malfunction caused by the use of parts other than manufacturer-specified genuine parts.
- 2) Malfunction caused by misuse or operating errors, or lack of storage or maintenance care.
- 3) Malfunction caused by the use of a fluid that may cause corrosion, inflation or dissolution of the component parts of the product.
- 4) Irregularity caused by a repair made by other than our firm, our regional office, dealer or authorized service personnel.
- 5) Malfunction caused by a modification of the product by other than authorized service personnel.
- 6) Wear and tear of parts that must be regularly replaced in the course of normal operation, such as diaphragms, valve seats, balls, air motor sleeve valves and o-rings.
- 7) Malfunction and/or damage due to transportation, moving or droppage of the product after purchase.
- 8) Malfunction and/or damage due to fire, earthquake, flood or other force majeure.
- 9) Malfunction caused by the use of compressed air that contains impurities, air with oil or excessive moisture, or use of gases or fluids other than the specified compressed air.
- 10) Malfunction caused by the use of a fluid that causes excessive abrasion.

Furthermore, this warranty does not cover the rubber parts, or other parts that are subject to wear in normal operation, used in this product and its accessories.

## 4. Parts

Parts for this product will be kept available for 5 years after discontinuation of production. Once 5 years have elapsed after close of production, availability of parts for this product cannot be guaranteed.

Notes:

A large grid of graph paper with rounded corners, intended for taking notes. The grid consists of 20 columns and 30 rows of small squares.

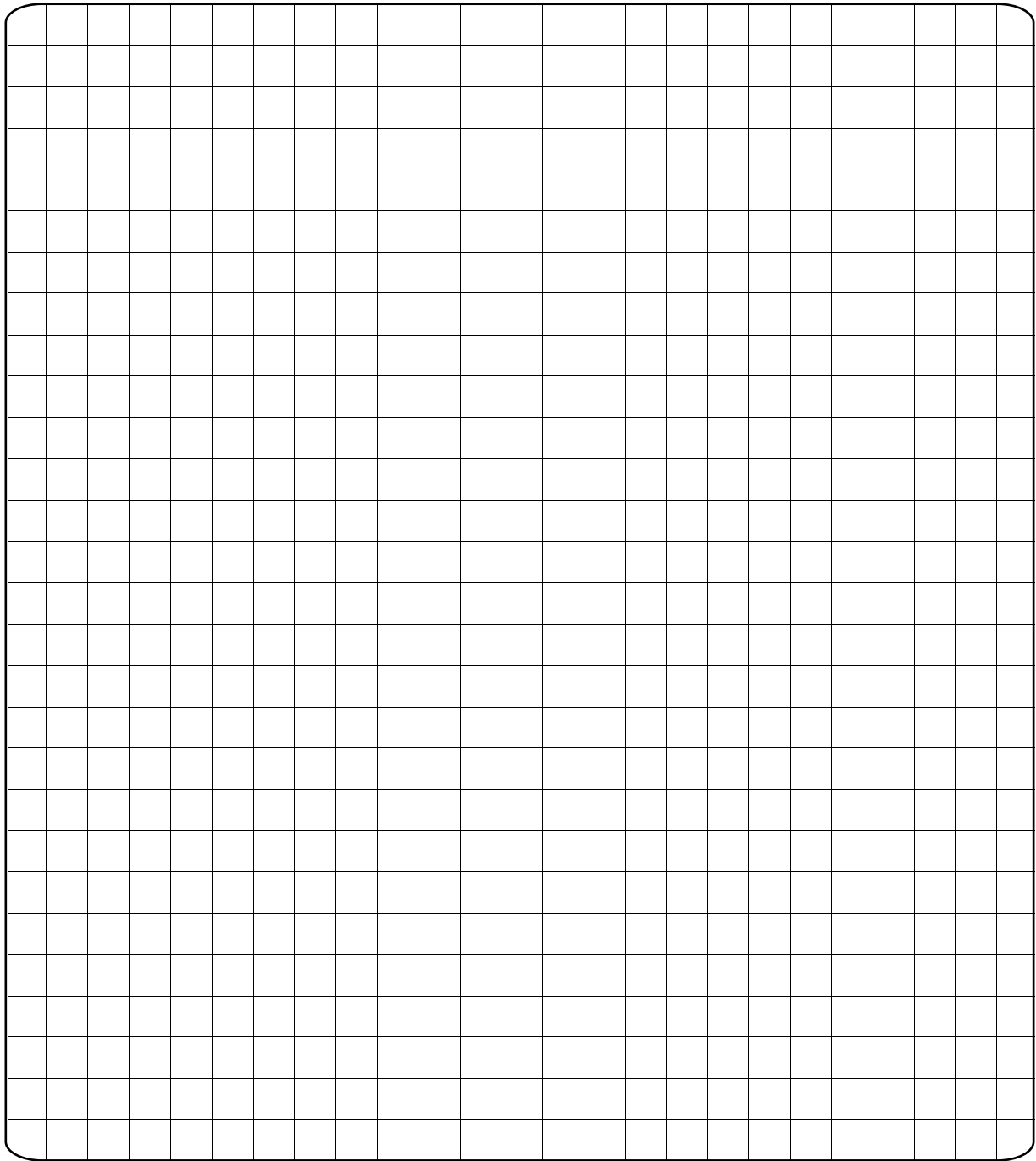

**DELLMECO LTD**

Unit 1, Willow Row  
Longton  
Stoke on Trent  
Staffordshire  
ST3 2PU  
United Kingdom  
tel. +44 1782 793 029  
fax: +44 1782 501 721



[sales@dellmeco.com](mailto:sales@dellmeco.com)  
[www.dellmeco.com](http://www.dellmeco.com)