

Specification Sheet

NovAseptic® Connector According to PED, Tube Standard DIN 11850 Reihe 1-3

Product Description

The NovAseptic® Connector is designed to meet the requirement of aseptic design. The product is adapted to be used as a connection for pipes, instruments, etc.

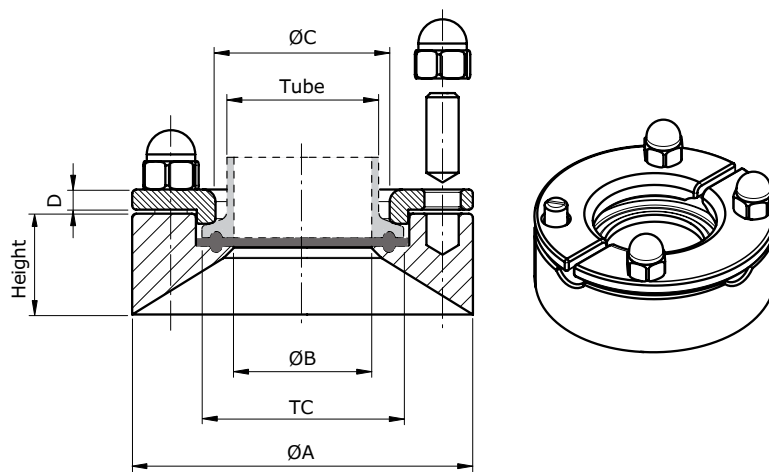

Catalogue No. Structure

NAC-D###/##

= Tube size (standard DIN11850 Reihe 1-3)

= Height

Nominal Dimensions in mm (in.)

Catalogue Number	NAC-D###/	Height	Tube	TC	A	B	C	D	Acorn Nut Size	Stud Size
NAC-D25/12	NAC-D25/	12	28.0-30.0 (1.102-1.181)	50.5	85.0 (3.346)	26.0 (1.024)	43.8 (1.724)	5.0 (0.197)	M8	M8 x 20
NAC-D25/25		25								
NAC-D25/38		38								
NAC-D25/51		51								
NAC-D40/12	NAC-D40/	12	40.0-42.0 (1.575-1.654)	50.5	85.0 (3.346)	38.0 (1.496)	43.8 (1.724)	5.0 (0.197)	M8	M8 x 20
NAC-D40/25		25								
NAC-D40/38		38								
NAC-D40/51		51								
NAC-D50/15	NAC-D50/	15	52.0-54.0 (2.047-2.126)	64	100.0 (3.937)	50.0 (1.969)	55.0 (2.165)	6.0 (0.236)	M8	M8 x 20
NAC-D50/25		25								
NAC-D50/38		38								
NAC-D50/51		51								
NAC-D65/15	NAC-D65/	15	70.0 (2.756)	91	131.0 (5.157)	66.0 (2.598)	78.0 (3.071)	10.0 (0.394)	M8	M8 x 25
NAC-D65/25		25								
NAC-D65/38		38								
NAC-D65/51		51								
NAC-D100/15	NAC-D100/	15	104.0 (4.094)	119	170.0 (6.693)	100.0 (3.937)	105.0 (4.134)	12.0 (0.472)	M8	M8 x 30
NAC-D100/25		25								
NAC-D100/38		38								
NAC-D100/51		51								

Specifications

Net Weight (approximate)																				
Connector	NAC-D25/				NAC-D40/				NAC-D50/				NAC-D65/				NAC-D100/			
	12	25	38	51	12	25	38	51	15	25	38	51	15	25	38	51	15	25	38	51
Weight kg (lb)	0.6 (1.3)	0.9 (2.0)	1.2 (2.65)	1.5 (3.31)	0.5 (1.1)	0.8 (1.8)	1.0 (2.20)	1.4 (3.09)	0.8 (1.8)	1.1 (2.43)	1.4 (3.09)	1.7 (3.75)	1.5 (3.31)	1.9 (4.19)	2.4 (5.29)	3.0 (6.61)	2.5 (5.51)	3.0 (6.61)	3.8 (8.38)	4.7 (10.4)

Material					
	Welding Flange		Locking Ring		Bolt and Nut
	Stainless Steel in Compliance with		Stainless Steel in Compliance with		Stainless Steel in Compliance with
Material Code	316L		EN 1.4435		EN 1.4401/ EN 1.4301
Technical Requirements	ASME® SA-479		EN 10272		EN 10269

Specifications	
Surface Roughness	Internal surface (manually polished) Ra ≤ 1.6 µm (63 µin)
Design Temperature	-80 to 200 °C (-112 to 392 °F)
Design Pressure	-1 to 7 bar(g) (-14.5 to 101 psi(g))
Note	The applied gasket (not included) may have different design temperature and/or pressure limits than the NovAseptic® Connector. The weakest component in the assembled product determines the maximum design temperature and pressure limits.
Labeling	Each NovAseptic® Connector is labeled for full LOT traceability and heat No. according to our QA routines.
Packaging	All open ends on the NovAseptic® Connector are protected with plastic covers on delivery. The NovAseptic® Connector is pre-assembled and packaged in a closed box.
Quality Control	Our Quality Assurance System guarantees the control and traceability of the product.
Regulatory	The NovAseptic® connectors are considered as component and not as pressurized accessory. Thus, the Pressure Equipment Directive (2014/68/EU) is not applicable. However, the design has been evaluated for assembly by welding on a vessel with a max allowable pressure of 7 bar and a max allowable temperature of 200 °C.
Options	For non-standard NovAseptic® Connector Options, please contact us for further information.

Technical Assistance

For more information, please visit SigmaAldrich.com
for up-to-date worldwide contact information

