

IMI PBM IGENIX® TWO-WAY BALL VALVES

Tank Bottom Steam Valves, FC Series 8 & 9, 1/2" - 6"



DESIGN FEATURES:

- Unique Adjust-O-Seal® feature allows in-line valve adjustment to compensate for normal wear on valve seats. Note: **FC Series Flush Tank Steam valves have o-rings.**
- Pad radius facilitates efficient drainage and reduces the pocket area above the ball.
- Upstream and downstream bubble-tight sealing capability allows valve body cleaning, purging, and draining.
- Stem assembly accommodates IMI PBM Direct Mount Actuation for accurate alignment and increased cycling life.
- Forged and cast valves are low-controlled ferrite.
- True-Bore® (valve bore same as connecting tubing) – no puddling
- ASME BPE compliant
- Available in Angle Stem versions for applications where automation may interfere with tank head or jacket.
- Valves are rated to full vacuum.
- Certified Material Test Report (CMTRS) provided for wetted components.
- Surface finishes are achieved without the use of ADIs (Animal Derived Ingredients).

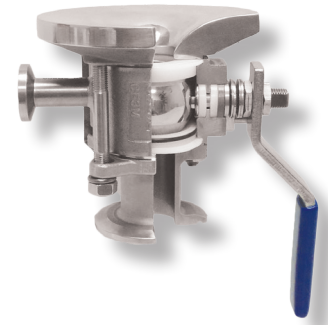

SPECIFICATIONS	Flush Tank Steam Valves
Sizes	1/2" - 6" Series 9, 1/2" - 4" Series 8
Material	316L, low ferrite cast and forged, Hastelloy™, AL6XN™, others
Temperatures	Ambient for V-TEF™ to 400° F, S-TEF® to 450° F
End Connections	Extended tube, hygienic clamp, compression ends (1/2" - 1")
Seats & Seals	White V-TEF™ standard, others available
O-rings	EPR O-ring energizer (Viton V1274-75/80, EPR E3608-70, others available)
Stem Packing Material	V-TEF™ and S-TEF®
Body Bolts & Nuts	18-8 Stainless Steel
Maximum Working Pressure	up to 600 psig CWP depending on valve series, size and temperature
Temperatures	up to 450° F depending on seat and seal material
Polish	Standard internal polish of 20 Ra ID Series 8, 30 Ra ID Series 9

CV Values (gpm), FC Series 8/Series 9	
Size	End Connection
	X-
1/2"	8.9
3/4"	34
1"	62
1-1/2"	175
2"	480
2-1/2"	870
3"	1,550
4"	3,750
6"	5,000

ID Surface Finish, Ra Readings for Valves per ASME BPE			
Surface Finish	IMI PBM Polish Code	μ-in.	μ-m.
Mechanical Polish			
SF 1	A	20 Ra max	0.51
SF 2	A	25 Ra max	0.64
SF 3	-	30 Ra max	0.76
Mechanical Polish and Electropolish			
SF 4	G	15 Ra max	0.38
SF 5	F	20 Ra max	0.51
SF 6	F	25 Ra max	0.64

How To Order:

PRODUCT (1-2)	SIZE (5)	END CONN. (7-8)	SEAT & SEAL (9)	WELD PAD (10-11)	BALL & STEM (12)	OPERATOR (13-14)	POLISH (15-16)
FC	HL Cast (Ser. 9) 316L S / S	C 1/2" 8	F - Ext. Butt weld for Tube	G V-TEF™ Seats / Seals FKM O-Rings	-- Standard Weld Pad	- Standard Ball and Stem	-- W/ Standard Lever Handle
	HF Forged 316L S / S	D 3/4" 9	X- Hygienic Clamp	J V-TEF™ Seats / Seals / VTFE Cav Fill / FKM O-Rings	02 w/o weld pad w/ shipping pad	F Internal / External Grounding	02 W/O Handle W/ Stem Actuator Prep
		E 1"	G- Female Cherry Burrell	Z V-TEF™ Seats / Seals EPR O-Rings		G 17-4PH Stem	04 Locking Lever Handle
		G 1-1/2"	H- Male Cherry Burrell	2 V-TEF™ Seats / Seals / VTFE Cav Fill / EPR O-Rings	Other Weld Pad Options available - Contact PBM.		08 Gear Operator (Req'd for 6")
		H 2"		H S-TEF® Seats / Seals FKM O-Rings			18 Extended Handle (2-1/2" thru 4")
		K 3"		0 S-TEF® Seats / Seals EPR O-Rings			71 Extended Handle (1/2" thru 2")
		L 4"		9 V-TEF™ Seats / Seals FEP Encaps. FKM O-Rings			20 DA 80psig actuator
		M* 6"	* Not available in forged				27 DA 60psig actuator
							34 SR 80psig actuator
							41 SR 60psig actuator

<http://pbmvalve.com/build-a-part-number>

Other Seat/seal options available - Contact PBM.

Other operator options available - Contact PBM.

More polish available - Contact PBM.

IMI PBM Igenix® Flush Tank Steam Valves, Manual

Flush Tank Valve with Locking Handle

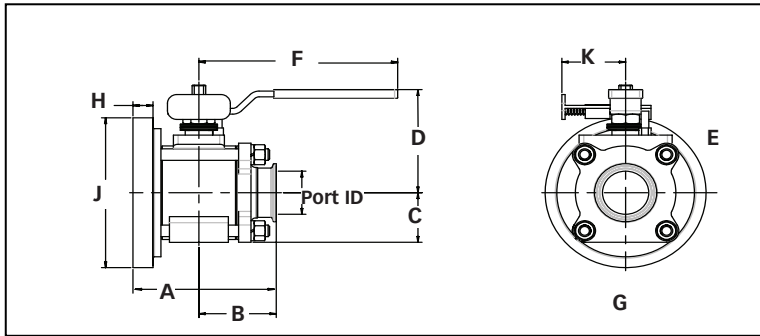

Flush Tank Valve with Gear Operator (6" only)

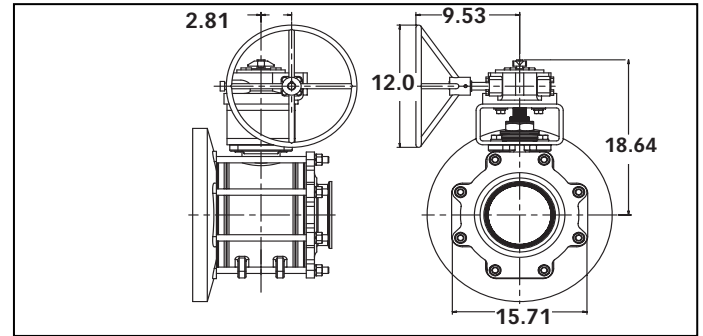

Flush Tank Sanitary Dimensioned valves in inches													Locking Handle	
Valve Size	Size Code	I.D. Port	A	B	C	D	E	F	G	H	J	Approx. Wgt (lbs)	K	Hole Dia. for Lock
1/2"	C	0.37	2.83	1.75	1.70	0.75	2.05	4.00	1.50	0.30	2.75	1.6	1.55	.28
3/4"	D	0.62	3.16	2.00	1.86	0.85	2.23	4.00	1.68	0.30	3.00	2	1.55	.28
1"	E	0.87	3.70	2.25	2.38	1.09	3.01	4.15	2.18	0.68	3.75	3.6	1.62	.25
1-1/2"	G	1.37	4.98	2.75	3.89	1.68	5.07	8.81	3.31	0.31	5.50	12	2.57	.38
2"	H	1.87	5.79	3.12	4.67	2.15	4.51	8.03	4.30	0.49	6.50	22	2.57	.38
3"	K	2.87	7.52	4.00	6.76	2.77	6.76	12.06	5.54	0.85	9.00	33	3.47	.38
4"	L	3.84	9.59	5.00	7.53	3.66	7.53	12.06	7.33	1.18	11.50	94	3.47	.38
6"*	M	5.78	12.78	6.50	12.14	6.18	NA	NA	12.36	1.34	17.00	164	NA	NA

*Cast Series 9 Only

ACTUATED DIMENSIONS

Unit of Measure = inches
Dimensions based on actuators used with V-TEF™ seats.

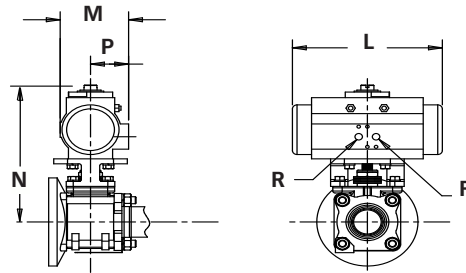

Size	80 PSI Spring Return					60 PSI Spring Return					60, 80 PSI Double Acting				
	L	M	N	P	R	L	M	N	P	R	L	M	N	P	R
1/2"	5.55	2.80	5.45	1.61	1/8 NPT	5.55	3.17	5.90	1.77	1/8 NPT	5.55	2.80	5.45	1.61	1/8 NPT
3/4"	5.55	2.80	5.59	1.61	1/8 NPT	6.46	3.17	6.04	1.77	1/8 NPT	5.55	2.80	5.59	1.61	1/8 NPT
1"	6.46	3.17	6.51	1.77	1/8 NPT	8.27	3.72	7.22	2.07	1/8 NPT	5.55	2.80	6.06	1.61	1/8 NPT
1-1/2"	9.47	4.17	9.65	2.30	1/8 NPT	10.83	4.84	9.65	2.68	1/4 NPT	8.27	3.72	9.10	2.07	1/8 NPT
2"	10.83	4.84	10.45	2.68	1/4 NPT	13.11	5.39	11.80	2.87	1/4 NPT	8.27	3.72	9.39	2.07	1/8 NPT
2-1/2"	13.11	5.39	13.48	2.87	1/4 NPT	14.65	5.83	13.96	3.15	1/4 NPT	13.11	5.39	13.48	2.87	1/4 NPT
3"	14.65	5.83	14.21	3.15	1/4 NPT	17.13	6.46	15.10	3.44	1/4 NPT	13.11	5.39	13.73	2.87	1/4 NPT
4"	17.13	6.46	15.86	3.44	1/4 NPT	19.69	7.32	16.80	3.90	1/4 NPT	13.11	5.39	14.51	2.87	1/4 NPT
6"	22.78	8.54	23.02	4.29	1/4 NPT	22.64	11.42	27.78	5.71	1/4 NPT	22.78	8.54	23.02	4.29	1/4 NPT



<http://www.pbmvalve.com/valves/tank-bottom-valve>

<http://pbmvalve.com/maintenance-instructions>

www.PBMValve.com

PBM, Inc. • 1070 Sandy Hill Road, Irwin, PA 15642

Phone: 800.967.4PBM • 724.863.0550

E-mail: info.pbmvalve@imi-critical.com



© Copyright 2018 PBM, Inc. PB-FC99